

**POWER
DRIVE**

User Manual

A800N Series Vector Inverter



Preface

Thank you for choosing Series AC DRIVE. This user manual presents a detailed description of series with respect to product features, structural characteristics, functions, installation, parameter setting, troubleshooting, etc. Be sure to carefully read through the safety precautions before use, and use this product on the premise that personnel and equipment safety is ensured.

IMPORTANT NOTES

- Please assure the intactness of product enclosure and all safety covers before installation .Operation must conform to the requirements of this manual and local industrial safety regulations and/or electrical codes.
- Contents of this manual may be subject to appropriate modification as a result of product upgrade, specification change and update of the manual.
- In the event of damage or loss of user manual, users may ask local distributors, offices or our Technical Service Department for a new one.
- If any item as stated in this manual is not clear, please contact for technical Service.
- If any anomaly occurs after power up or during the operation, it is essential to stop the machine and identify the fault or seek technical services as soon as possible.

Contents

Chapter 1 Product Information

1.1 Model Explanation.....	6
1.2 Nameplate Information.....	6
1.3 Information of Product Model.....	7
1.4 System Connection Diagram.....	9

Chapter 2 Technical Features

2.1 Specifications.....	12
2.2 Structure diagram.....	14
2.3 Product Size.....	15
2.4 Keyboard size.....	17

Chapter 3 Main Circuit Terminals and Wiring

3.1 Main Circuit Terminals.....	21
3.2 Control Terminal Wiring.....	22
3.3 Wiring Diagram.....	23
3.4 Control Terminal Specification.....	24
3.5 Control Terminal Usage.....	25

Chapter 4 Operation and Display Interface

4.1 Introduction to Operation and Display Interface.....	28
--	----

Chapter 5 Parameter Table

Parameter Table.....	40
----------------------	----

Chapter 6 Detailed function description

Group P0: Basic function group	78
Group P1: Motor Parameters.....	88
Group P2: Vector Control Parameters of Motor.....	92
Group P3: V/f Control Parameters of Motor.....	95
Group P4: Analog and Pulse Input.....	100
Group P5: Analog and Pulse Output.....	108
Group P6: Start/Stop Control.....	114

Group P7: Keys of Control panel.....	120
Group P8: Auxiliary setting of operating frequency.....	124
Group P9: Protection Parameters.....	136
Group PA: Process PID.....	144
Group PB: Fixed length counting parameter.....	151
Group PC: Multi-segment instructions, simple PLC.....	153
Group PD MODBUS Communication Parameters.....	157
Group PP Function code management.....	158
Group A0: Torque Control Parameters.....	159
Group A5: Control optimization parameters.....	161
Group U0: Basic monitoring parameters.....	163

Chapter 7 EMC attention

7.1 EMC Definition.....	172
7.2 Introduction to EMC standards.....	172
7.3 EMC Guidance.....	172

Chapter 8 EMC attention

8.1 Table of Fault Codes.....	178
-------------------------------	-----

Warranty

Warranty Card

Certificate of quality



Chapter 1

Product Information

1.1 Model Explanation.....	6
1.2 Nameplate Information.....	6
1.3 Information of Product Model.....	7

1.1 Model Explanation

Model shown on product nameplate indicates the series name, applicable type of power supply, power class and the version of software and hardware, etc. via the combination of numbers, symbols and letters.

1
2
3
4

Code	No.	Content
Voltage level	①	2 : 220V 4 : 380V
Voltage Classification	②	S : Single-phase T : Three phase
Adapted motor power	③	0.4KW~400KW
Model	④	Heavy-duty

1.2 Nameplate Information

Model: 4T-4.0G

Power: 4.0KW

Input: 3PH/380V 15A 50Hz/60Hz

Input: 3PH/380V 9.4A 0Hz-600Hz



CEEG3AFBC134212

1.3 Information of Product Model

Drive model	Power rating (kW)	3-phase rated output current(A)	1-phase rated input current(A)	3-phase rated input current(A)	Applicable motor (kW)	Brake chopper
Single/ three-phase 220V input, heavy duty						
2S-0.4G	0.4	2.8	5.5	3.2	0.4	Inbuilt
2S-0.7G	0.75	4.8	9.2	6.3	0.75	
2S-1.5G	1.5	8.0	14.5	9	1.5	
2S-2.2G	2.2	10	23	15	2.2	
2S-4.0G	3.7	17	35	20.5	3.7	

Drive model	Power rating (kW)	3-phase rated output current(A)	3-phase rated input current(A)	Applicable motor (kW)	Brake chopper
Three-phase 220V input, heavy duty					
2T-5.5G	5.5	25	29	5.5	Inbuilt
2T-7.5G	7.5	30	35	7.5	
2T-11G	11	45	50	11	
2T-15G	15	60	65	15	
2T-18.5G	18.5	75	80	18.5	
2T-22G	22	90	95	22	
2T-30G	30	110	118	30	

Drive model	Power rating (kW)	Rated output current(A)	Rated input current(A)	Applicable motor (kW)	Brake chopper
Three-phase 400V input, heavy duty/ light duty					
4T-0.7G	0.75	2.8	3.5	0.75	Inbuilt
4T-1.5G	1.5	4.3	5.0	1.5	
4T-2.2G	2.2	5.6	6.0	2.2	
4T-4.0G	3.7	9.4	10.5	3.7	
4T-5.5G	5.5	13	14.6	5.5	
4T-7.5G	7.5	17	20.5	7.5	

Drive model	Power rating (kW)	Rated output current(A)	Rated input current(A)	Applicable motor (kW)	Brake chopper
4T-11G	11	25	29	11	Inbuilt
4T-15G	15	30	35	15	
4T-18.5G	18.5	37	44	18.5	Inbuilt optional
4T-22G	22	45	50	22	
4T-30G	30	60	65	30	
4T-37G	37	75	80	37	
4T-45G	45	90	95	45	
4T-55G	55	110	118	55	
4T-75G	75	150	157	45	
4T-90G	90	176	180	90	-
4T-110G	110	210	215	110	-
4T-132G	132	253	232	132	-
4T-160G	160	310	285	160	-
4T-185G	185	350	326	185	-
4T-200G	200	380	354	200	-
4T-220G	220	430	403	220	-
4T-250G	250	470	441	250	-
4T-280G	280	520	489	280	-
4T-315G	315	590	571	315	-
4T-355G	355	650	624	355	-
4T-400G	400	725	700	400	-

Note:

- Means brake chopper is optionally inbuilt. Braking resistor needs to be mounted externally:
- Means the rated input current configured a DC reactor. The drive 4T2000B - 4T4000B is provided with an external-mounted DC reactor in shipment as default. Be sure to connect the DC reactor. Failure to comply may result in drive abnormal run.

1.4 System Connection Diagram

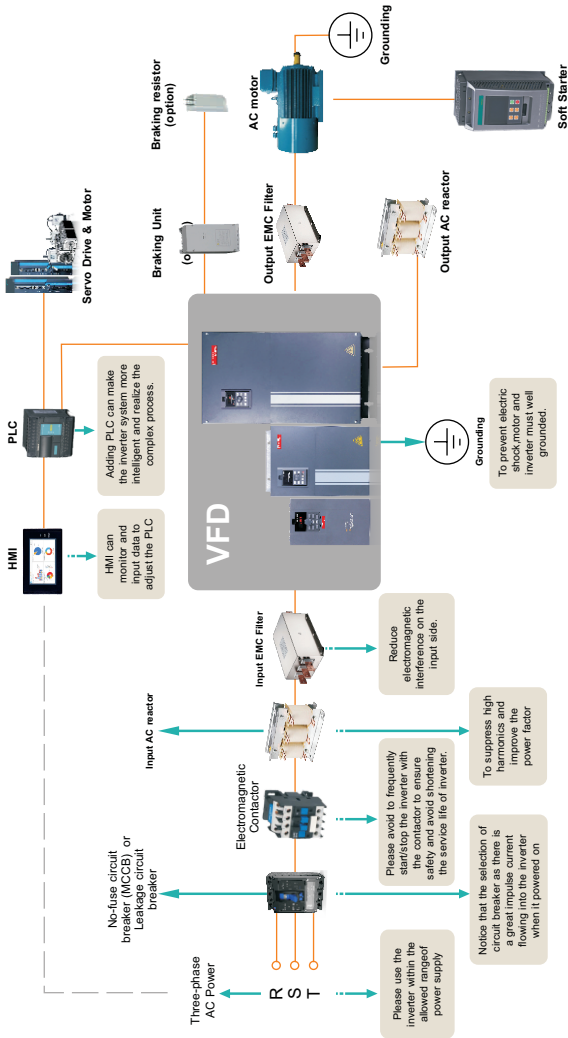



Chapter 2

Technical Features

2.1 Specifications.....	10
2.2 Structure diagram.....	12
2.3 Product Size.....	13
2.4 Keyboard size.....	15

2.1 Specifications

Items		Specifications
Power Input	Rated input voltage	3-phase AC208V/AC220V/AC230V/AC240V/AC380V/ AC400V/AC415V/AC440V/AC460V/AC480V 1-phase AC220V/AC230V/AC240V
	Frequency	50Hz/60Hz, tolerance $\pm 5\%$
	Voltage range	Continuous voltage fluctuation $\pm 10\%$, short fluctuation - 15%~+10%, i.e. 200V: 170V~264V, 400V: 323V~528V Voltage out-of-balance rate <3%, distortion rate as per the requirements of IEC61800-2
	Rated input current	See Table 1-1
Power output	Applicable motor(kW)	See Table 1-1
	Rated current(A)	See Table 1-1
	Output voltage(V)	3-phase: 0~rated input voltage, error< $\pm 3\%$
	Output frequency(Hz)	0.00~600.00Hz; unit: 0.01Hz
	Overload capacity	150%-1min, 180%-10s, 200%-0.5s every 10min
Control characteristics	V/f patterns	V/f control Sensor-less vector control
	Range of speed regulation	1:100 (V/f control) 1:200 (sensor-less vector control)
	Speed accuracy	$\pm 0.5\%$ (V/f control) $\pm 0.2\%$ (sensor-less vector control)
	Speed fluctuation	$\pm 0.3\%$ (sensor-less vector control)
	Torque response	<10ms (sensor-less vector control)
	Starting torque	0.5Hz: 180% (V/f control, sensor-less vector control)
Basic functions	Start frequency	0.00~600.00Hz
	Accel/Decel time	0.00~60000s
	Switching frequency	0.7kHz~16kHz
	Frequency setting	Digital setting + control panel \wedge / \vee Digital setting + terminal UP/DOWN Communication Analog setting (AI1/AI2) Terminal pulse setting

	Items	Specifications
Basic functions	Motor start-up methods	Started from starting frequency DC brake start-up Flying start
	Motor stop methods	Ramp to stop Coast to stop Ramp stop + DC brake
	Dynamic braking capacity	Brake chopper working voltage: 200V level: 325-375V / 400V level: 650V-750V Service time: 0-100.0s; brake chopper for 4T0150B and below are inbuilt or can be inbuilt optionally.
	DC brake capacity	DC brake start frequency: 0.00~600.00Hz DC brake current: 0.0~100.0% DC brake time: 0.0~30.00s
	Input terminals	6 digital inputs, one of which can be used for high-speed pulse input, and compatible with active open collectors NPN, PNP and dry contact input. 2 analog inputs, one of which is voltage/current programmable, and the other supports voltage only. and the extended one is voltage/current programmable
	Output terminals	1 high-speed pulse output, 0~50kHz square wave signal output. It can output signals such as frequency setting, or output frequency, etc. 1 digital output 1 relay output (can be extended to 2) 1 analog output (can be extended to 2), voltage/current output programmable; can output signals such as frequency setting, or output frequency, etc.
Featured functions	Parameter copy, parameter backup, flexible parameter displayed & hidden, various master & auxiliary setting and switchover, flying start, a variety of Accel/Decel curves optional, automatic correction of analog, brake control, 16-step speed control programmable (2-step speed supports flexible frequency command), wobble frequency control, count function, three history faults, over excitation brake, over voltage stall protection, under voltage stall protection, restart on power loss, skip frequency, frequency binding, four kinds of Accel/Decel time, motor thermal protection, flexible fan control, process PID control, simple PLC, multi-functional key programmable, droop control, autotuning, field-weakening control, V/f separated control.	

Items		Specifications
Environment	Place of operation	Indoors, no direct sunlight, free from dust, corrosive gases, flammable gases, oil mist, water vapor, water drop or salt, etc.
	Altitude	0-2000m. De-rate 1% for every 100m when the altitude is above 1000 meters
	Ambient temperature	-10℃-40℃. The rated output current should be derated 1% for every 1℃ when the ambient is 40℃--60℃
	Relative humidity	0~95%, no condensation
	Vibration	Less than 5.9m/s ² (0.6g)
	Storage temperature	-40℃~+70℃
Others	Efficiency at rated Amps	Rated power 7.5kW and below: ≥93% 11~ 45kW: ≥ 95% 55kW and above: ≥98%
	IP grade	IP20
	Cooling method	Forced air cooling

2.2 Structure diagram

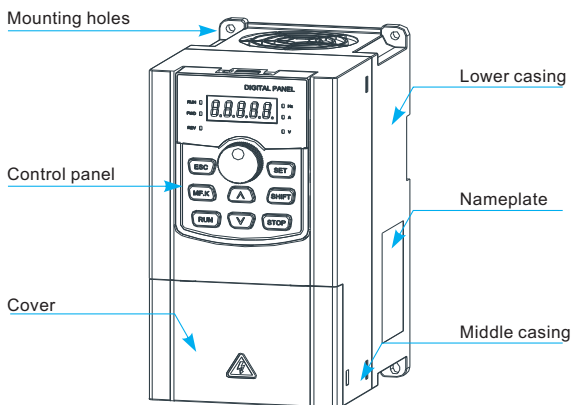

2.3 Product Size

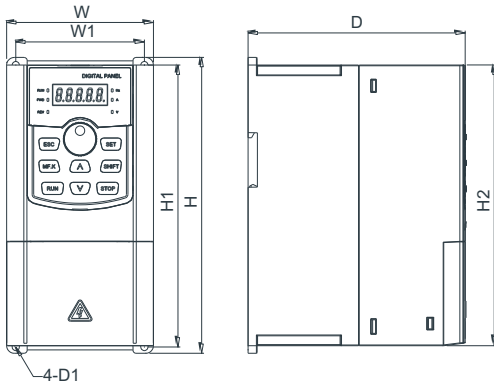

Model	External and installation dimensions (mm)						Pore size	Weight (kg)
	W1	H1	H	H2	W	D		
2S-0.7G	67.5	160	170	----	84.5	129	Φ4.5	1.0
2S-1.5G								
4T-1.5G								
4T-2.2G								
2S-2.2G	85	185	194	----	97	143.5	Φ5.5	1.4
2S-4.0G								
4T-4.0G								
4T-5.5G								
2T-5.5G	106	233	245	----	124	171.2	Φ5.5	2.5
4T-7.5G								
4T-11G								
2T-7.5G	120	317	335	----	200	178.2	Φ8	8.4
2T-11G								
4T-15G								
4T-18.5G								
4T-22G								

Chapter 2 Technical Features

Model	External and installation dimensions (mm)						Pore size	Weight (kg)
	W1	H1	H	H2	W	D		
2T-15G	150	387.5	405	----	255	195	Φ8	12.8
2T-18.5G								
4T-30G								
4T-37G	180	437	455	----	300	225	Φ10	17.8
2T-22G								
2T-30G								
4T-45G								
4T-55G	260	750	785	----	395	291	Φ12	50
4T-75G								
4T-90G								
4T-110G	360	950	990	----	500	368	Φ14	88
4T-132G								
4T-160G								
4T-185G								
4T-200G	400	1000	1040	----	650	406	Φ14	123
4T-220G								
4T-250G								
4T-280G	600	1250	1300	----	815	428	Φ14	165
4T-315G								
4T-355G								
4T-400G								

2.4 keyboard size

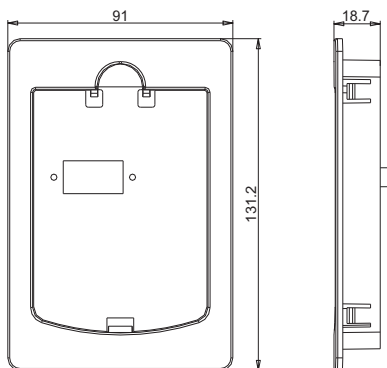

External dimension of external keyboard

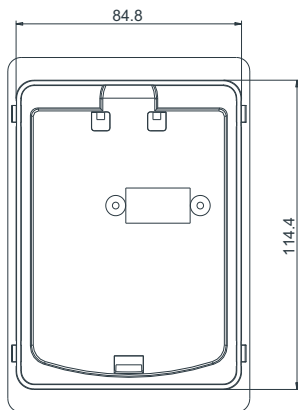

Installation opening size of external keyboard



Chapter 3

Main Circuit Terminals and Wiring

3.1 Main Circuit Terminals.....	19
3.2 Control Terminal Wiring.....	20
3.3 Wiring Diagram.....	21
3.4 Control Terminal Specification.....	22
3.5 Control Terminal Usage.....	23



WARNING

- Only qualified personnel familiar with AC motor drives are allowed to implement wiring. Failure to comply may result in equipment damage and/or personnel injury even death.
- Wiring should be in strict accordance with this manual, otherwise hazard of electric shock or equipment damage exists.
- Make sure input power supply has been completely disconnected before wiring operation. Failure to comply will result in personnel injury even death.
- All wiring operations and lines should comply with EMC and national and local industrial safety regulations and/or electrical codes. The conductor diameter should be in accordance with recommendations of this manual. Otherwise, hazard of equipment damage, fire, and/or personnel injury exists.
- Since leakage current of the drive may exceed 3.5mA, for safety's sake, the drive and the motor must be grounded so as to avoid hazard of electric shock.
- Be sure to perform wiring in strict accordance with the drive terminal marks. Never connect three-phase power supply to output terminals U/T1, V/T2 and W/T3. Failure to comply will result in equipment damage.



ATTENTION

- Signal wires should be away from main power lines to the best of possibility. In the event that this cannot be ensured, vertical cross arrangement should be adopted, reducing EMI interference to the signal wires as much as possible.
- In case the motor cable exceeds 100m, an appropriate output reactor should be mounted.

3.1 Main Circuit Terminals

Terminal marks	Designation and function of terminals
R/L、S/L2、T/L3	Single / Three-phase AC input terminals (Connect R/L1, T/L3 when use single phase input)
⊕、B1	Braking resistor connection terminals
U/T1、V/T2、W/T3	Three-phase AC output terminals
⊕	Ground terminal PE

- ◇ Main circuit terminal of three-phase 380V frequency converter

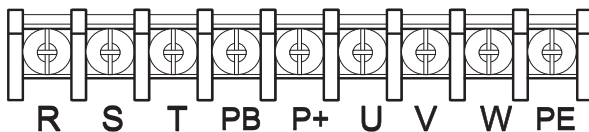

- ◇ Specification of three-phase / single-phase converter main circuit terminal 220V

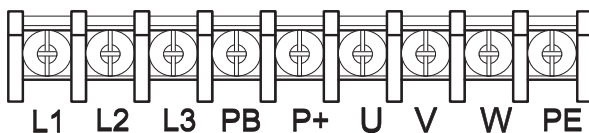

3.2 Control Terminal Wiring



WARNING

- Only qualified personnel familiar with AC motor drives are allowed to implement wiring. Failure to comply may result in equipment damage and/or personnel injury even death.
- Wiring should be in strict accordance with this manual, otherwise hazard of electric shock or equipment damage exists.
- Make sure input power supply has been completely disconnected before wiring operation. Failure to comply will result in personnel injury even death.
- All wiring operations and lines should comply with EMC and national and local industrial safety regulations and/or electrical codes. The conductor diameter should be in accordance with recommendations of this manual. Otherwise, hazard of equipment damage, fire, and/or personnel injury exists.
- Screws or bolts for terminal wiring must be screwed tightly.
- AC 220V signal is prohibited from connecting to terminals other than control terminals RA, RB and RC.



ATTENTION

- Signal wires should be away from main power lines to the best of possibility. If this cannot be ensured, vertical cross arrangement should be adopted, reducing EMI interference to the signal wires as much as possible.
- The encoder must be provided with shielded cables whose shielded layer must be properly grounded.

3.3 Wiring Diagram

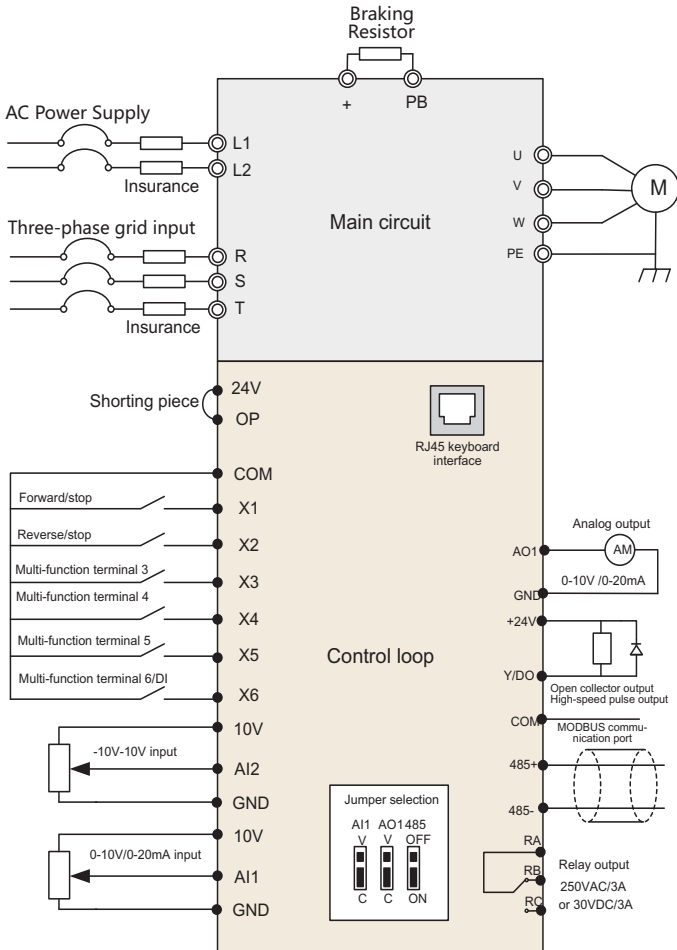

3.4 Control Terminal Specification

Category	Terminal	Terminal designation	Description
Analog input	+10V	Analog input reference voltage	10.1V \pm 3%
			Maximum output current 25mA The resistance of external potentiometer should be larger than 400 Ω
	GND	Analog ground	Isolated from COM interiorly
	AI1	Analog input 1	0~20mA: input impedance -500 Ω , maximum input current - 25mA
			0~10V: input impedance -22k Ω , maximum input voltage -12.5V Switch AI1 on control board for jumping from 0~20mA and 0~10V, factory default: 0~10V
AI2	Analog input 2	-10V~10V: input impedance - 25k Ω	
		Range: -12.5V~+ 12.5V	
Analog output	AO1	Analog output 1	0~20mA: impedance - 200 Ω ~500 Ω
			0~10V: impedance \geq 10k
			Switch AO1 on control board for jumping between 0~20mA and 0~10V, factory default: 0~10V
GND	Analog ground	Isolated from COM interiorly	
Digital input	+24V	+24V	24V \pm 10%, Isolated from GND interiorly
			Maximum load - 200mA
	PLC	Digital input Common terminal	Used for switching between high and low levels, short-circuited with +24V when delivery, i.e. low value of digital input valid
			External power input
	COM	+24V ground	Isolated from GND interiorly
	X1~X5	Digital input Terminals 1~5	Input: 24VDC, 5mA
Range of frequency: 0~200Hz Range of voltage: 10V~30V			
X6/DI	Digital input/pulse input	Digital input: same as X1~X5 Pulse input: 0.1Hz~50kHz; range of voltage: 10-30V	

Category	Terminal	Terminal designation	Description
Digital output	Y	Open collector output	Range of voltage: 0~24V Range of current: 0~50mA
	Y/DO	Open collector out / Pulse out	Open collector output: same as Y Pulse output: 0~50kHz
Relay output	RA/RB /RC	Control board relay output	RA-RB: NC; RA-RC: NO
			Contact capacity: 250VAC/3A, 30VDC/3A
Terminal 485 Interface	485+	485 differential signal +	Rate: 4800/9600/19200/38400/57600/115200bps
	485-	485 differential signal -	Maximum distance - 500m (standard network cable used)
	GND	485 communication shield grounding	Isolated from COM interiorly
Control panel		Control panel SPI interface	Maximum communication distance is 3m when connected to Control panel
			Use standard network cable

3.5 Control Terminal Usage

◇ Lay-out of Control Terminals

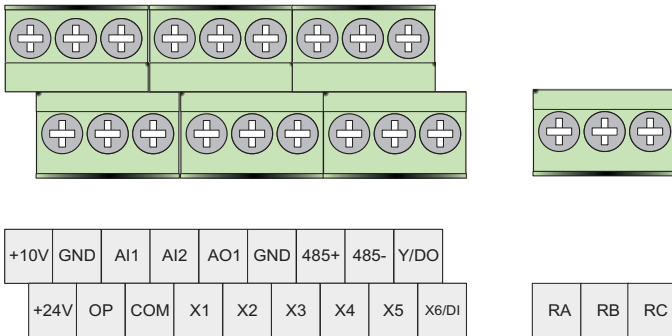

◇ Instruction of Signal Switches

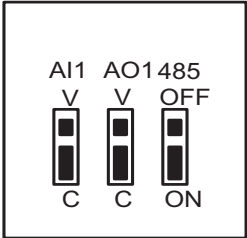



Chapter 4

Operation and Display Interface

4.1 Introduction to Operation and Display Interface.....	26
4.2 Description of function code viewing and modification method.....	27

4.1 Introduction to Operation and Display Interface

The operation panel can be used to modify the function parameters of the product, monitor the working status of the product and control the operation of the product (start and stop). The appearance and function area are shown in the following figure:

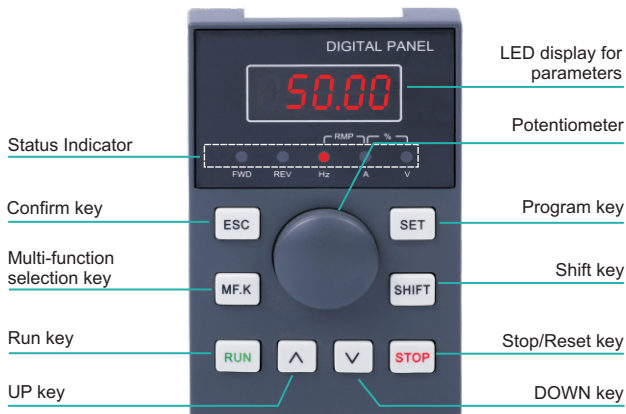

Figure 4-1 Schematic diagram of operation panel

4.1.1 Introduction to Indicators

Name		Function Description				
Status indicator	FWD/REV	When the machine is stopped, when the Fwd lamp is on, it indicates that the product forward rotation command is valid; when the machine is running, it indicates that the product is running in the forward rotation state; when Fwd flashes, it shows that the product is switching from the forward rotation state to the reverse rotation state. When the machine is stopped, the rev lamp is on, indicating that the reverse rotation command of the product is valid, or the reverse operation state. When the rev lamp flashes, indicating that the product is switching from the reverse rotation state to the forward rotation state.				
Unit indicator	Hz	Frequency unit	A	Current unit	V	Voltage unit
	RMP	(Hz + A) units	%	(A + V) percent		
Digital display	5-digit led display, which can display the set frequency, output frequency, various monitoring data and alarm code, etc.					

4.1.2 LED Display

The five-digit LED data display can show the frequency reference, output frequency, monitoring information, and fault code.

LED display	Indication	LED display	Indication	LED display	Indication
0	0	1	1	2	2
3	3	4	4	5	5, S
6	6	7	7	8	8
9	9	A	A	b	B
C	C	c	c	d	D
E	E	F	F	L	L
n	N	P	P	r	D
T	T	U	U	u	u

4.1.3 Keys on LED Operating Panel

Key	Key Name	Function
ESC	Programming key	Level 1 Menu Entry or Exit
SET	Confirm key	Enter the menu screen step by step, and confirm the parameter settings
∧	Incremental Key	Increment of data or function code
V	Decreasing key	Decrement of data or function code
SHIFT	Shift key	Under the shutdown display interface and the operation display interface, the display parameters can be cyclically selected; When modifying a parameter, you can select the modification bit of the parameter
RUN	Run Key	In the keyboard mode of operation, used to run the operation
STOP	Stop/Reset	In running status, press this key to stop running operation; In fault alarm state, it can be used for reset operation, and the characteristics of this key are governed by function code P7-16.
MK.F	Multifunction selection key	Select function switch according to P7-00

4.1.4 View and Modify Function Parameters

The drive operating panel has three levels of menu:

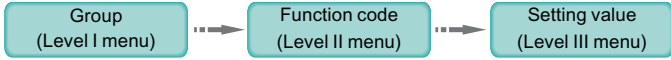

After entering each level of menu, you can press \wedge , \vee or **SHIFT** to modify the flashing value.

Operation procedure is shown in Figure 4-2.

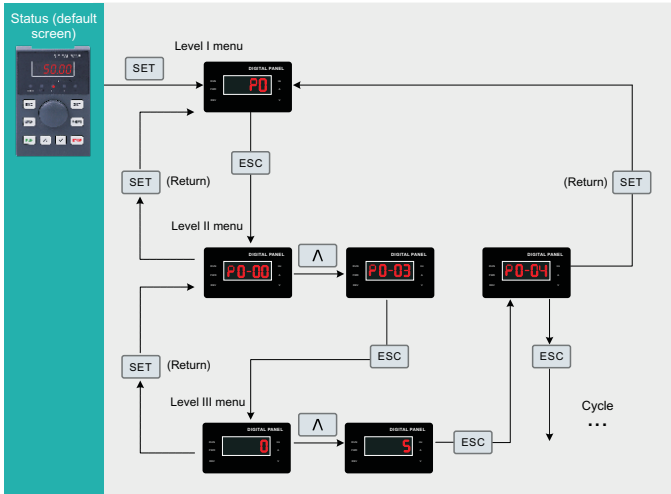

Figure 4-2 Operation procedure of the three levels of menu

The following example shows how to modify P3-02 from 10.00 Hz to 15.00 Hz.

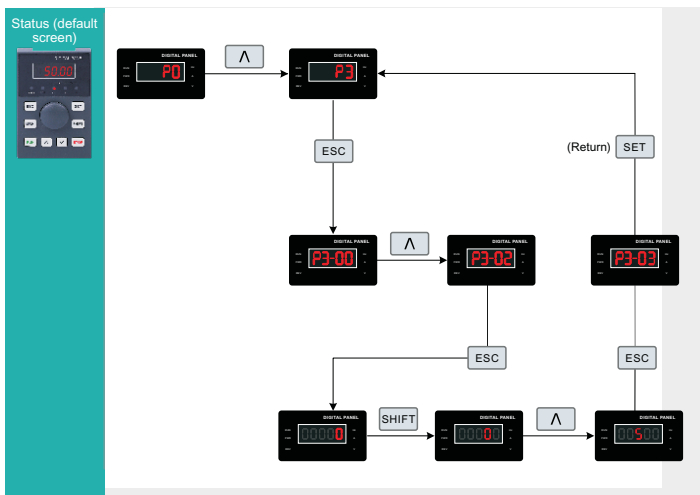

Figure 4-3 How to modify the parameter value

- ❶ Press **SET** or **ESC** from a Level III menu to return to a Level II menu. The difference between the two keys is: **ESC** is used to save the parameter value you have set, return to Level II menu and then select the next function parameter. **SET** is used to return to Level II menu without saving the parameter value and remain at the current parameter.
- ❷ (When operating in Level III menus, if the parameter does not include a flashing digit, then it is not possible to modify that parameter. There are two possible reasons for this:
 - The function parameter you have selected is read-only. This is because the display is showing the AC drive model; the display is showing an actual parameter detected by the system; or the display is showing a running record parameter.
 - The displayed function parameter cannot be modified while the AC drive is in the RUNNING status. You can modify these types of parameter only when the AC drive is in the STOP status.

4.1.5 Overall Arrangement of Function Parameters

Table 4-4 Overall arrangement of function parameters.

Par.	Designation	Scope
P0 to PP	Basic function parameters	Displays parameters such as running commands, frequency commands, motor parameters, control modes, AI/AO characteristic correction, and optimization control
A0 to AC		
U0	Monitoring function parameter group	Displays basic monitoring parameters

Before viewing function parameters, set PP-02 (SELECTED) to see whether the function parameter group is displayed. The following figure shows how to view the function parameter group number:

Par.	Designation	Scope	Default	Attr
PP-02	Function parameter group display selection	Ones place: U group display selection 0: not displayed 1: Display Tens place: P group display selection 0: not displayed 1: Display	11	☆

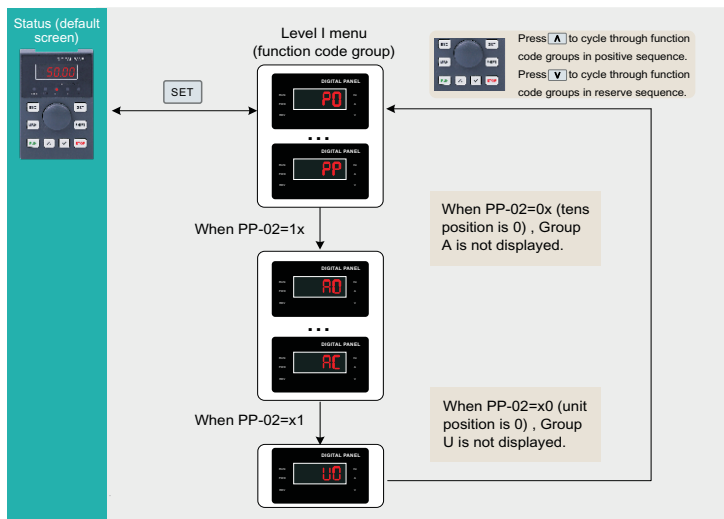

Figure 4-4 View the function parameter group number

4.1.6 View Function Parameters

The drive provides three display modes for viewing parameters. In base mode, all function parameters are shown. You can set PP-03 to quick view function parameters in two other modes.

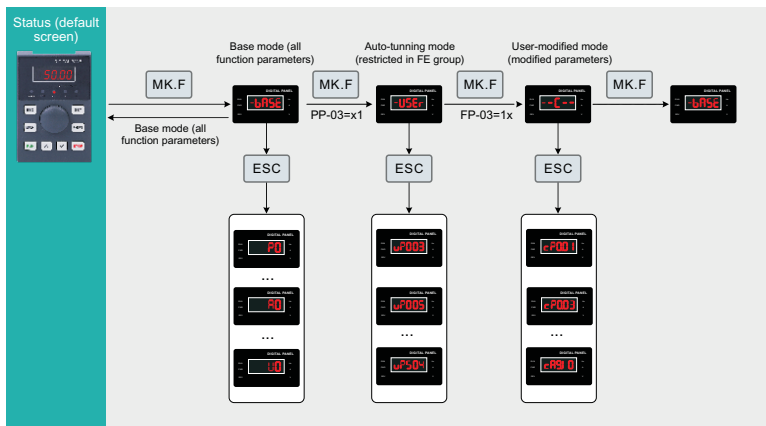

Figure 4-5 View the function parameters

In the figure above, in user-defined quick-view mode, the parameter is displayed as "uP3.02". It means the parameter P3-02 can be modified in user-modified quick-view mode and base mode in the same way.

Function parameter display modes are as follows:

Mode	Display	Description
User-defined quick-view mode		Show function parameters that are defined by a user
User-modified quick-review mode		Show function parameter whose value is different from the default value
Base mode		Show all function parameters in sequence

1. Base mode

In base mode, all function parameters of the drive are shown. You can view or edit the parameters according to section 4.2. Press **[MK.F]** to cycle through three function parameter display modes. In each mode, the method you use to view and modify parameter value is the same as shown in 4.2.

2. Quick-view mode

To show function parameters that are defined or modified by a user, set the PP-03 value to 11.

Par.	Designation	Setting Range	Description	Default
PP-03	Function parameter group display selection	Unit's digit: -USER group is displayed 0: Not displayed; 1: Displayed Ten's digit: --C-- group is displayed. 0: Not displayed; 1: Displayed	Determine whether the operating panel displays quick-view user-defined and quick-view user modified function groups.	00

■ View quick-view user-defined function parameter group

Press **[MK.F]** to enter the **-USER** mode. Then the user can view the user-defined function parameters.

The user can set the function group PE (PE-00 to PE-29) to define often used function parameters. The user can define up to 30 parameters to the function group PE. The function parameters PE00 to PE-15 (16 in total) are default and can be edited by the user. If a parameter in group FE is set to P0.00, it indicates that no Parameter is defined by the user. If "**NULL**" is displayed after you press **[MK.F]**, it indicates that the userdefined menu is empty. The following table lists the often used parameters in the user-defined menu.

Parameter No.	User-defined Parameter No.	Name
PE-00	P0-01	Control mode
PE-01	P0-02	Command source selection
PE-02	P0-03	Main frequency reference setting channel selection

Parameter No.	User-defined Parameter No.	Name
PE-03	P0-07	Frequency source calculation selection
PE-04	P0-08	Preset frequency
PE-05	P0-17	Acceleration time
PE-06	P0-18	Deceleration time
PE-07	P3-00	V/F curve setting
PE-08	P3-01	Torque boost
PE-09	P4-00	DI1 function selection
PE-10	P4-01	DI2 function selection
PE-11	P4-02	DI3 function selection
PE-12	P5-04	DO1 output selection
PE-13	P5-07	AO1 output selection
PE-14	P6-00	Start mode
PE-15	P6-10	Stop mode

■ View user modified function parameters

Press **[MK.F]** to enter the **--C--** mode to view function parameters that have been modified.

In this mode, you can view modified function parameters quickly. All function parameters that have been modified by a user are listed in the modified function parameter group. The current values of these parameters are different from the default values. The AC drive automatically generated a list of modified function parameters.

3. View status parameters

When the drive in STOP or RUNNING state, press **[SHIFT]** to switch each byte of P7-03, P7-04, an P7-05 to display multiple status parameters.

A maximum of 32 parameters in the running status can be viewed in P7-03 (running parameter 1) and P7-04 (running parameter 2) based on each bit selection in binary. At stop, a total of 13 parameters can be viewed in P7-05 (STOP parameter) based on each bit selection in binary.

You can use the operating panel to view running frequency, bus voltage, output voltage, output current, output power and PID reference.

- ❶ Set each bit of P7-03 to 1 according to the mapping between each bit and the corresponding parameter.
- ❷ Convert binary number to equivalent hexadecimal number. H.001F is displayed.
- ❸ Press **SHIFT** to convert each bit of P7-03. The reference is as follows:

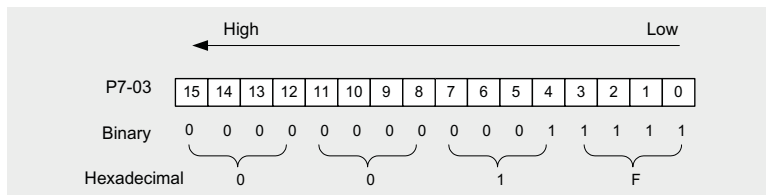

You can view the other parameters in the same way. The mapping of each bit of FP-03, FP-04, and FP-05 is shown in the following figure:

Par.	Parameter Name	Default	Setting Range	Description																																																																																																																																																									
P7-03	LED display running parameters 1	1F	0000 to FFFF	<p>If a parameter needs to be displayed during running, set corresponding bit to 1, and set F7-03 to hexadecimal equivalent.</p> <table border="1" style="margin-left: 20px;"> <tr> <td>7</td><td>6</td><td>5</td><td>4</td><td>3</td><td>2</td><td>1</td><td>0</td> <td>LOWEST EIGHT DIGITS</td> </tr> <tr> <td colspan="7"></td> <td>0</td> <td>Running frequency (Hz)</td> </tr> <tr> <td colspan="7"></td> <td>1</td> <td>Frequency reference (Hz)</td> </tr> <tr> <td colspan="7"></td> <td>2</td> <td>Bus voltage (V)</td> </tr> <tr> <td colspan="7"></td> <td>3</td> <td>Output voltage (V)</td> </tr> <tr> <td colspan="7"></td> <td>4</td> <td>Output current (A)</td> </tr> <tr> <td colspan="7"></td> <td>5</td> <td>Output power (kW)</td> </tr> <tr> <td colspan="7"></td> <td>6</td> <td>DI state (V)</td> </tr> </table> <table border="1" style="margin-left: 20px;"> <tr> <td>15</td><td>14</td><td>13</td><td>12</td><td>11</td><td>10</td><td>9</td><td>8</td> <td>HIGHEST EIGHT DIGITS</td> </tr> <tr> <td colspan="7"></td> <td>8</td> <td>DO state</td> </tr> <tr> <td colspan="7"></td> <td>9</td> <td>AI1 voltage (V)</td> </tr> <tr> <td colspan="7"></td> <td>10</td> <td>AI2 voltage (V)</td> </tr> <tr> <td colspan="7"></td> <td>11</td> <td>AI3 voltage (V)</td> </tr> <tr> <td colspan="7"></td> <td>12</td> <td>Count value</td> </tr> <tr> <td colspan="7"></td> <td>13</td> <td>Length value</td> </tr> <tr> <td colspan="7"></td> <td>14</td> <td>Load speed display</td> </tr> <tr> <td colspan="7"></td> <td>15</td> <td>PID reference</td> </tr> </table> <p>Note: Values with shading are default values.</p>	7	6	5	4	3	2	1	0	LOWEST EIGHT DIGITS								0	Running frequency (Hz)								1	Frequency reference (Hz)								2	Bus voltage (V)								3	Output voltage (V)								4	Output current (A)								5	Output power (kW)								6	DI state (V)	15	14	13	12	11	10	9	8	HIGHEST EIGHT DIGITS								8	DO state								9	AI1 voltage (V)								10	AI2 voltage (V)								11	AI3 voltage (V)								12	Count value								13	Length value								14	Load speed display								15	PID reference
7	6	5	4	3	2	1	0	LOWEST EIGHT DIGITS																																																																																																																																																					
							0	Running frequency (Hz)																																																																																																																																																					
							1	Frequency reference (Hz)																																																																																																																																																					
							2	Bus voltage (V)																																																																																																																																																					
							3	Output voltage (V)																																																																																																																																																					
							4	Output current (A)																																																																																																																																																					
							5	Output power (kW)																																																																																																																																																					
							6	DI state (V)																																																																																																																																																					
15	14	13	12	11	10	9	8	HIGHEST EIGHT DIGITS																																																																																																																																																					
							8	DO state																																																																																																																																																					
							9	AI1 voltage (V)																																																																																																																																																					
							10	AI2 voltage (V)																																																																																																																																																					
							11	AI3 voltage (V)																																																																																																																																																					
							12	Count value																																																																																																																																																					
							13	Length value																																																																																																																																																					
							14	Load speed display																																																																																																																																																					
							15	PID reference																																																																																																																																																					

Par.	Parameter Name	Default	Setting Range	Description
P7-04	LED display running parameters 2	0	0000 to FFFF	<p>If a parameter needs to be displayed during running, set corresponding bit to 1, and set F7-04 to hexadecimal equivalent.</p> <p>LOWEST EIGHT DIGITS</p> <ul style="list-style-type: none"> 7: PID feedback 6: PLC stage 5: Input pulse frequency (kHz) 4: Running frequency 2 (Hz) 3: Remaining running time 2: AI1 voltage before correction (V) 1: AI2 voltage before correction (V) 0: AI3 voltage before correction (V) <p>HIGHEST EIGHT DIGITS</p> <ul style="list-style-type: none"> 15: Motor speed 14: Current power-on time (H) 13: Current running time (Min) 12: Input pulse frequency (Hz) 11: Communication reference 10: Reserved 9: Main frequency display (Hz) 8: Auxiliary frequency display (Hz)
P7-05	LED display stop parameters	3	0000 to FFFF	<p>If a parameter needs to be displayed during stop, set corresponding bit to 1, and set F7-05 to hexadecimal equivalent.</p> <p>LOWEST EIGHT DIGITS</p> <ul style="list-style-type: none"> 7: Frequency reference (Hz) 6: Bus voltage (V) 5: DI state 4: DO state 3: AI1 voltage (V) 2: AI2 voltage (V) 1: AI3 voltage (V) 0: Count value <p>HIGHEST EIGHT DIGITS</p> <ul style="list-style-type: none"> 15: Length value 14: PLC stage 13: Load speed 12: PID reference 11: Input pulse frequency (Hz) 10: Reserved 9: Reserved 8: Reserved

4.1.7 MF.K Key Function

Function of the **MF.K** key on the LED operating panel can be set using parameter P7-01. You can switch over running command or frequency reference direction of the drive and implement forward/reverse jog through this key in either STOP or RUNNING status.

Par.	Parameter Name	Default	Setting Range	Description
P7-01	key function selection	0	0: MF.K disabled	The key has no function.
			1. Switchover between operating panel and terminal/communication.	F0-02=0, there is no effect after you press the MF.K key. F0-02=1, running command can be switched over between terminal and operating panel through the MF.K key. F0-02=2, communication source can be switched over between communication and operating panel through the MF.K key.
			2. Forward /Reverse RUN switchover	Frequency reference direction can be switched over through the MF.K key. This function is valid only when running command is operating panel.
			3: Forward jog	Forward jog of the drive can be implemented through the MF.K key. This function is valid only when running command is operating panel.
			4: Reverse jog	Reverse jog of the drive can be implemented through the MF.K key. This function is valid only when running command source is operating panel.



Chapter 5

Parameter Table

Parameter Table.....	32
----------------------	----

Change property description

"☆": The parameter can be changed when it is running, stopped, not locked by the keyboard and parameters;

"★": The parameters can be changed in the shutdown state, not locked by the keyboard and parameters, and the running state cannot be changed;

"●": Monitoring parameters, which cannot be changed.

Par.	Designation	Scope	Default	Attr
Group P0: Basic function group				
P0-00	GP type display	1: G type (constant torque load type) 2: P type (fan, water pump load)	1	●
P0-01	1st motor control method	0: Speed sensorless vector control (SVC) 1: With speed sensor vector control (FVC) 2: V/F control	2	★
P0-02	Run command selection	0: Operation panel 1: Terminal 2: Communication	3	☆
P0-03	Master FREQ set	0: Digital setting (no memory when power off) 1: Digital setting (power-down memory) 2: AI1 3: AI2 4: Panel potentiometer 5: Pulse setting (X6) 6: Multi-segment instruction 7: Simple PLC 8: PID 9: Communication given	4	★
P0-04	Auxiliary frequency source input selection	The definition is the same as A0-03 (main frequency command input selection)	0	★
P0-05	Auxiliary frequency command range selection	0: Relative to the maximum frequency 1: Relative to the main channel	1	☆
P0-06	Frequency auxiliary given coefficient	0%~150%	100%	☆

Par.	Designation	Scope	Default	Attr
P0-07	Main and auxiliary frequency superposition selection	<p>Ones place: frequency command selection</p> <p>0: Main frequency command</p> <p>1: Main and auxiliary operation results</p> <p>2: Switch between main frequency command and auxiliary frequency command</p> <p>3: Switch between the main frequency command and the main and auxiliary operation results</p> <p>4: Switch between the auxiliary frequency command and the main and auxiliary operation results</p> <p>Ten's place: main and auxiliary operation relationship of frequency command</p> <p>0: main + auxiliary</p> <p>1: Primary-Secondary</p> <p>2: the maximum value of the two</p> <p>3: the minimum value of the two</p>	0	☆
P0-08	Digital frequency setting	Upper limit FREQ ~600.00Hz	50.00Hz	☆
P0-09	Run direction	<p>0: Forward</p> <p>1: Reverse</p>	0	☆
P0-10	Maximum FREQ	Upper limit FREQ ~600.00Hz	50.00Hz	★
P0-11	Upper limit frequency command selection	<p>0: A0-12 setting</p> <p>1: Ai1</p> <p>2: Ai2</p> <p>3: Panel potentiometer</p> <p>4: Pulse setting</p> <p>5: Communication given</p>	0	★
P0-12	Upper limit FREQ	Lower limit frequency A0-14~Maximum frequency A0-10	50.00Hz	☆
P0-13	Upper limit frequency offset	0.00Hz~Maximum frequency A0-10	0.00Hz	☆
P0-14	Lower limit FREQ	0.00Hz~upper limit FREQ	0.00Hz	☆
P0-15	Switching FREQ	0.5kHz~16.0kHz, factory default	Model dependent	☆

Chapter 5 Parameter Table

Par.	Designation	Scope	Default	Attr
P0-16	The carrier frequency is adjusted with the size of the load	0: No 1: Yes	1	☆
P0-17	Accel time 1	0.0~65000	Model dependent	☆
P0-18	Decel time 1	0.0~65000	Model dependent	☆
P0-19	Accel/Decel time resolution	0: 0.01s 1: 0.1s 2: 1s	1	★
P0-21	Auxiliary frequency command offset frequency when superimposed	0.00Hz~Maximum frequency A0-10	0.00Hz	☆
P0-23	Digital setting frequency stop memory selection	0: No memory 1: Memory	0	☆
P0-25	Acceleration and deceleration time reference frequency	0: Maximum frequency (A0-10) 1: Set frequency	0	★
P0-26	Frequency command UP/DOWN reference during operation	0: Running frequency 1: Set frequency	0	★
P0-27	Running command bundled main frequency command selection	Units digit: selection of binding frequency source on operation panel 0: no binding 1: Digital setting frequency 2: AI1 3: AI2 4: Panel potentiometer 5: Pulse setting (X6) 6: Multi-speed 7: Simple PLC 8: PID 9: Communication given Tens place: terminal binding frequency source selection Hundreds place: Communication binding frequency source selection	0	☆

Par.	Designation	Scope	Default	Attr
Group P1 Motor Parameters				
P1-00	Type of motor	0: Ordinary motor 1: Variable frequency motor	0	★
P1-01	Power rating of motor	0.4kW~630kW	Model dependent	★
P1-02	Motor rated voltage	1V~1000V	Model dependent	★
P1-03	Motor rated current	0.01A~6553.5A	Model dependent	★
P1-04	Motor rated frequency	0.01Hz~upper limit frequency	Model dependent	★
P1-05	Rated speed of motor	1~65535r/min	Model dependent	★
P1-06	Motor stator resistance	0.001Ω~65.535Ω (Inverter power ≤ 55kW) 0.0001Ω~6.5535Ω (Inverter power >55kW)	Self-learning parameters	★
P1-07	Motor rotor resistance	0.001Ω~65.535Ω (Inverter power ≤ 55kW) 0.0001Ω~6.5535Ω (Inverter power >55kW)	Self-learning parameters	★
P1-08	Motor leakage inductance	0.01mH~655.35mH (Inverter power ≤ 55kW) 0.001mH~65.535mH (Inverter power >55kW)	Self-learning parameters	★
P1-09	Motor mutual inductance	0.01mH~655.35mH (Inverter power ≤ 55kW) 0.001mH~65.535mH (Inverter power >55kW)	Self-learning parameters	☆
P1-10	Motor no-load current	0.01A~P1-03 (Inverter power ≤ 55kW) 0.1A~P1-03 (Inverter power >55kW)	Self-learning parameters	☆
P1-27	Number of encoder lines	1~65535	2500	★

Chapter 5 Parameter Table

Par.	Designation	Scope	Default	Attr
P1-28	Encoder type	0: ABZ incremental encoder 2: Resolver	0	★
P1-30	ABZ incremental encoder AB phase sequence	0: Positive 1: Reverse	0	★
P1-34	Number of pole pairs of resolver	1~65535	1	★
P1-36	Speed feedback PG disconnection detection time	0.0s: no action 0.1s~10.0s	0.0s	★
P1-37	Tuning selection	0: no operation 1: Parameter tuning of the static part of the asynchronous machine 2: Dynamic complete tuning of asynchronous machines 3: Asynchronous motor static complete tuning	0	★
Group P2 Vector Control Parameters of Motor				
P2-00	Speed loop low speed proportional gain	1~100	30	☆
P2-01	Speed loop low speed integration time	0.01s~10.00s	0.50s	☆
P2-02	Speed loop low-speed switching frequency	0.00~P2-05	5.00Hz	☆
P2-03	Speed loop high speed proportional gain	1~100	20	☆
P2-04	Speed loop high-speed integration time	0.01s~10.00s	1.00s	☆
P2-05	Speed loop high-speed switching frequency	P2-02~Maximum frequency	10.00Hz	☆
P2-06	Vector control slip gain	50%~200%	100%	☆
P2-07	SVC speed feedback filter time	0.000s~0.100s	0.015s	☆

Par.	Designation	Scope	Default	Attr
P2-09	Torque upper limit command selection in speed control mode	0: Function code P2-10 setting 1: AI1 2: AI2 3: Panel potentiometer 4: Pulse (X6) 5: Communication given 6: MIN (Ai1, AI2) 7: MAX (Ai1, AI2) The full scale of options 1-7 corresponds to P2-10	0	☆
P2-10	Digital setting of torque upper limit in speed control mode	0.0%~200.0%	140%	☆
P2-11	Torque upper limit command selection in speed control mode (power generation)	0: Function code P2-12 setting (do not distinguish between motor and generator) 1: AI1 2: AI2 3: Panel potentiometer 4: Pulse (X6) 5: Communication given 6: MIN (AI1, AI2) 7: MAX (Ai1, AI2) 8: Function code P2-12 setting The full scale of options 1-7 corresponds to P2-12	0	☆
P2-12	Digital setting of torque upper limit in speed control mode (power generation)	0.0%~200.0%	150%	☆
P2-13	Excitation adjustment proportional gain	0~60000	2000	☆
P2-14	Excitation adjustment integral gain	0~60000	1300	☆
P2-17	Velocity Loop Integral Properties	Units: Integral separation 0: Invalid 1: Valid	0	☆
P2-18	Weakening mode selection	0: Disable 1: Only deceleration is enabled 2: Constant speed and deceleration enable	0	☆

Par.	Designation	Scope	Default	Attr
P2-19	Overmodulation enable selection	0: Disable 1: enable	0	☆
P2-20	Voltage Overmodulation Coefficient	100-110%	105	☆
P2-21	Maximum torque coefficient in field weakening region	50-200	100	☆
P2-22	Generating torque enable selection in speed mode	0: Invalid 1: Valid	0	☆
Group P3 V/f Control Parameters of Motor				
P3-00	V/f curve setting	0: Straight line V/F 1: Multi-point V/F 2~9: reserved 10: V/F fully separated mode 11: V/F half separation mode	0	★
P3-01	Torque boost	0.0%: (without torque boost) 0.1%~30.0%	Model dependent	☆
P3-02	Torque boost cut-off frequency	0.00Hz~Maximum frequency	50.00Hz	★
P3-03	Multipoint V/F Frequency Point 1	0.00Hz~P3-05	0.00Hz	★
P3-04	Multipoint V/F Voltage Point 1	0.0%~100.0%	0.0%	★
P3-05	Multipoint V/F Frequency Point 2	P3-03~P3-07	0.00Hz	★
P3-06	Multipoint V/F Voltage Point 2	0.0%~100.0%	0.0%	★
P3-11	V/F oscillation suppression factor	0~100	40	☆
P3-13	V/F separated voltage source	0: Digital setting (P3-14) 1: AI1 2: AI2 4: PULSE pulse setting (X6) 5: Multi-segment instruction 6: Simple PLC 7: PID 8: Communication given Note: 100.0% corresponds to the rated voltage of the motor	0	☆

Par.	Designation	Scope	Default	Attr
P3-14	Voltage digital setting for V/F separation	0V~motor rated voltage	0V	☆
P3-15	Voltage acceleration time for V/F separation	0.0s~1000.0s Note: Indicates the time from 0V to the rated voltage of the motor	0.0s	☆
P3-16	Voltage deceleration time for V/F separation	0.0s~1000.0s Note: Indicates the time from 0V to the rated voltage of the motor	0.0s	☆
P3-17	V/F separation and stop mode selection	0: Frequency/voltage is reduced to 0 independently 1: After the voltage is reduced to 0, the frequency is reduced again	0	☆
P3-18	Overcurrent suppression level	50~200%	150%	★
P3-19	Selection of overcurrent suppression effectiveness	0: Invalid 1: Valid	1	★
P3-20	Overcurrent Suppression Gain	0~100	20	☆
P3-21	Overcurrent Stall Action Current Compensation Coefficient	50~200%	50%	★
P3-22	Overvoltage stall action voltage	650.0V~800.0V	770	★
P3-23	Overvoltage Stall Enable	0: Invalid 1: Valid	1	★
P3-24	Overvoltage stall suppression frequency gain	0~100	30	☆
P3-25	Overvoltage Stall Suppression Voltage Gain	0~100	30	☆
P3-26	Overvoltage stall maximum rising frequency limit	0~50Hz	5Hz	★

Par.	Designation	Scope	Default	Attr
Group P4 Analog and Pulse Input				
P4-00	Function of terminal X1	0: No function 1: Forward running FWD 2: Run REV in reverse 3: Three-wire running control 4: Forward jog (FJOG) 5: Reverse Jog (RJOG)	0	★
P4-01	Function of terminal X2	6: Terminal UP 7: Terminal DOWN 8: Free parking 9: Fault reset (RESET) 10: Run pause 11: External fault normally open input 12: Multi-segment command terminal 1 13: Multi-segment command terminal 2 14: Multi-segment command terminal 3 15: Multi-segment command terminal 4 16: Acceleration and deceleration time selection terminal 1 17: Acceleration and deceleration time selection terminal 2	4	★
P4-02	Function of terminal X3	18: Frequency command switching 19: UP/DOWN setting clear 20: Control command switching terminal 1 21: Acceleration and deceleration prohibition	9	★
P4-03	Function of terminal X4	22: PID pause 23: Simple PLC state reset 24: Swing frequency pause 25: Counter input 26: Counter reset 27: Length count input 28: Length reset	12	★
P4-04	Function of terminal X5	29: Torque control prohibited 30: Pulse frequency input (only valid for X6) 32: Immediate DC braking 33: External fault normally closed input 34: Frequency modification enable	13	★
P4-05	Function of terminal X6		0	★

Par.	Designation	Scope	Default	Attr
		35: PID action direction is reversed 36: External parking terminal 1 37: Control command switching terminal 2 38: PID integral pause 39: Switch between main frequency and preset frequency 40: Switch between auxiliary frequency and preset frequency 41: Motor terminal selection function 42: reserved 43: PID parameter switching 44: User-defined fault 1 45: User-defined fault 2 46: Speed control/torque control switching 47: Emergency stop 48: External parking terminal 2 49: Deceleration DC braking		
P4-10	DI filter time	0.000s~1.000s	0.010s	☆
P4-11	Terminal command method	0: Two-wire type 1 1: Two-wire type 2 2: Three-wire type 1 3: Three-wire type 2	0	★
P4-12	Terminal UP/DOWN change rate	0.001Hz/s~65.535Hz/s	0.0s	☆
P4-13	AI curve 1 minimum input	0.00V~P4-15	0.00V	☆
P4-14	AI curve 1 minimum input corresponding setting	-100.0%~+100.0%	0.00%	☆
P4-15	AI curve 1 maximum input	P4-13~+10.00V	10.00V	☆
P4-16	AI curve 1 maximum input corresponding setting	-100.0%~+100.0%	100.00%	☆
P4-17	AI1 filter time	0.00s~10.00s	0.10s	☆
P4-18	AI curve 2 minimum input	0.00V~P4-20	0.00V	☆

Chapter 5 Parameter Table

Par.	Designation	Scope	Default	Attr
P4-19	AI curve 2 minimum input corresponding setting	-100.0%~+100.0%	0.00%	☆
P4-20	AI curve 2 max input	P4-18~+10.00V	10.00V	☆
P4-21	AI curve 2 maximum input corresponding setting	-100.0%~+100.0%	100.0%	☆
P4-22	AI2 filter time	0.00s~10.00s	0.10s	☆
P4-23	AI Curve 3 Minimum Input	-10.00V~P4-25	-10.00V	☆
P4-24	AI curve 3 minimum input corresponding setting	-100.0%~+100.0%	-100.00%	☆
P4-25	AI curve 3 max input	P4-23~+10.00V	10.00V	☆
P4-26	AI curve 3 maximum input corresponding setting	-100.0%~+100.0%	100.0%	☆
P4-27	AI3 filter time	0.00s~10.00s	0.10s	☆
P4-28	Pulse input minimum frequency	0.00kHz~P4-30	0.00kHz	☆
P4-29	Pulse minimum input frequency corresponding setting	-100.0%~+100.0%	0.00%	☆
P4-30	Pulse maximum input frequency	P4-28~100.00kHz	50.00 kHz	☆
P4-31	Pulse maximum input frequency corresponding setting	-100.0%~+100.0%	100.0%	☆
P4-32	Pulse filter time	0.00s~10.00s	0.10s	☆
P4-33	AI curve selection	Ones place: AI1 curve selection 1: Curve 1 (2 points, see P4-13~P4-16) 2: Curve 2 (2 points, see P4-18~P4-21) 3: Curve 3 (2 points, see P4-23~P4-26) Tens place: AI2 curve selection 1: Curve 1 (2 points, see P4-13~P4-16) 2: Curve 2 (2 points, see P4-18~P4-21) 3: Curve 3 (2 points, see P4-23~P4-26)	321	☆

Par.	Designation	Scope	Default	Attr
P4-34	AI is lower than the minimum input setting selection	Ones place: AI1 is lower than the minimum input setting selection 0: corresponds to the minimum input setting 1: 0.0% Tens place: AI2 is lower than the minimum input setting selection 0: corresponds to the minimum input setting 1: 0.0%	0	☆
P4-35	X1 delay time	0.0s~3600.0s	0.0s	★
P4-36	X2 delay time	0.0s~3600.0s	0.0s	★
P4-37	X3 delay time	0.0s~3600.0s	0.0s	★
P4-38	Digital input terminal X valid mode selection 1	0: Active high 1: Active low Ones place: X1 Ten place: X2 Hundreds: X3 Thousands: X4 Ten thousand: X5	0	★
P4-39	Digital input terminal X valid mode selection 2	0: Active high 1: Active low Ones place: X6	0	★
Group P5 Analog and Pulse Output				
P5-00	Y/DO output function selection	0: Pulse output (DO) 1: Switch output (Y)	0	☆
P5-01	Y terminal function selection (open collector output terminal)	0: No output 1: The inverter is running 2: Fault output (stop) 3: Frequency level detection 1 4: Frequency arrives 5: Running at zero speed (no output when stopped)	0	☆
P5-02	Control board relay function selection (TA-TB-TC)	6: Motor overload pre-alarm 7: Inverter overload pre-alarm 8: Set the count value to reach 9: The specified count value arrives	2	☆

Par.	Designation	Scope	Default	Attr
		10: length arrives 11: PLC cycle completed 12: Accumulated running time arrives 13: Frequency limiting 14: Torque limited 15: Ready to run 16: AI1 > Ai2 17: The upper limit frequency is reached 18: The lower limit frequency is reached (operation related) 19: Undervoltage status output 20: Communication settings 21: Positioning completed (reserved) 22: Positioning close (reserved) 23: Running at zero speed 2 (also output when stopped) 24: Cumulative power-on time arrives 25: Frequency level detection FDT2 output 26: Frequency 1 arrives at the output 27: Frequency 2 arrives at the output 28: Current 1 reaches the output 29: Current 2 reaches the output 30: Timed arrival output 31: AI1 input overrun 32: Dropping 33: Reverse running 34: Zero current state 35: Module temperature reached 36: The output current exceeds the limit 37: The lower limit frequency is reached (the output is also output when the machine is stopped) 38: Alarm output (continue running)		

Par.	Designation	Scope	Default	Attr
P5-06	DO output function selection	0: Running frequency 1: set frequency 2: output current 3: Motor output torque (absolute value, percentage relative to the motor) 4: Output power	0	☆
P5-07	AO output function selection	5: Output voltage 6: Pulse input (100.0% corresponds to 100.0kHz) 7: Ai1 8: Ai2 9: Reserved 10: length 11: count value	0	☆
P5-08	Reserve	12: Communication settings 13: Motor speed 14: Output current (100.0% corresponds to 1000.0A) 15: Output voltage (100.0% corresponds to 1000.0V) 16: Motor output torque (actual value, percentage relative to motor)	1	☆
P5-09	DO output maximum frequency	0.01kHz~100.00kHz	50.00kHz	☆
P5-10	AO zero bias coefficient	0	0.00%	☆
P5-11	AO gain	-10.00~+10.00	1	☆
P5-17	DO output delay time	0.0s~3600.0s	0.0s	☆
P5-18	Relay output delay time	0.0s~3600.0s	0.0s	☆
P5-20	DO output delay time	0.0s~3600.0s	0.0s	☆
P5-22	DO output terminal valid state selection	-100.0%~+100.0%	0	☆
Group P6 Start/Stop Control				
P6-00	Start method	0: direct start 1: Speed tracking restart 2: Pre-excitation start (AC asynchronous machine)	0	☆

Chapter 5 Parameter Table

Par.	Designation	Scope	Default	Attr
P6-01	Speed tracking method	0: start from stop frequency 1: Start from the power frequency 2: start from maximum frequency	0	★
P6-02	Speed tracking speed	1~100	20	☆
P6-03	Start frequency	0.00Hz~10.00Hz	0.00Hz	☆
P6-04	Start frequency hold time	0.0s~100.0s	0.0s	★
P6-05	Start DC braking current /pre-excitation current	0%~100%	50%	★
P6-06	Start DC braking time/pre- excitation time	0.0s~100.0s	0.0s	★
P6-07	Acceleration and deceleration method	0: Linear acceleration and deceleration 1, 2: Dynamic S-curve acceleration and deceleration	0	★
P6-08	The proportion of time at the beginning of the S- curve	0.0%~(100.0%-P6-09)	30.00%	★
P6-09	The proportion of time at the end of the S-curve	0.0%~(100.0%-P6-08)	30.00%	★
P6-10	Stop mode	0: Decelerate to stop 1: Free parking	0	☆
P6-11	DC braking starting frequency at stop	0.00Hz~Maximum frequency	0.00Hz	☆
P6-12	DC braking waiting time at stop	0.0s~100.0s	0.0s	☆
P6-13	Stop DC braking current	0.0%~100.0%	50%	☆
P6-14	DC braking time at stop	0.0s~100.0s	0.0s	☆
P6-15	Brake usage ratio	0.0%~100.0%	100%	☆
P6-18	Speed tracking current size	30%~200%	Model dependent	★
P6-21	Demagnetization time (SVC valid)	0.00~5.00s	Model dependent	☆
Group P7 Keys of Control panel				
P7-00	Reserve	-	-	-

Par.	Designation	Scope	Default	Attr
P7-01	MF key setting	0: MF.K is invalid 1: Switch between the operation panel command channel and the remote command channel (terminal command channel or communication command channel) 2: Forward and reverse switching 3: Forward jog 4: Reverse jog 5: Panel PID setting is valid	0	★
P7-02	STOP/RESET key function	0: STOP/RES key stop function is only valid in keyboard operation mode 1: The stop function of the STOP/RES key is valid for any running channel	1	☆
P7-03	Run display parameter 1	0000~FFFF Binary settings: Ones digit selection XXXXX (BIT 3-2-1-0) Bit00: Running frequency 1 (Hz) Bit01: Set frequency (Hz) Bit02: Bus voltage (V) Bit03: Output voltage (V) Ten digit selection XXXXX (BIT 3-2-1-0) Bit04: Output current (A) Bit05: Output power (kW) Bit06: Output torque (%) Bit07: X terminal input status Hundreds place selection XXXXX (BIT 3-2-1-0) Bit08: DO output status Bit09: AI1 voltage (V) Bit10: AI2 voltage (V) Bit11: Reserved Thousands place option XXXXX (BIT 3-2-1-0) Bit12: count value Bit13: length value Bit14: Load speed display Bit15: PID setting	1F	☆

Par.	Designation	Scope	Default	Attr
P7-04	Run display parameter 2	0000~FFFF Binary settings: Ones digit selection XXXXX (BIT 3-2-1-0) Bit00: PID feedback Bit01: PLC stage Bit02: PULSE input pulse frequency (kHz) Bit03: Running frequency 2 (Hz) Ten digit selection XXXXX (BIT 3-2-1-0) Bit04: Remaining running time Bit05: AI1 voltage before correction (V) Bit06: AI2 voltage before correction (V) Bit07: Reserved Hundreds place selection XXXXX (BIT 3-2-1-0) Bit08: Linear speed Bit09: Current power-on time (Hour) Bit10: Current running time (Min) Bit11: PULSE input pulse frequency (Hz) Thousands place option XXXXX (BIT 3-2-1-0) Bit12: Communication setting value Bit13: Encoder feedback speed (Hz) Bit14: Main frequency X display (Hz) Bit15: Auxiliary frequency Y display (Hz)	0	☆
P7-05	Stop display parameters	0000~FFFF Binary settings: Ones digit selection XXXXX (BIT 3-2-1-0) Bit00: Set frequency (Hz) Bit01: Bus voltage (V) Bit02: X input status Bit03: DO output status Ten digit selection XXXXX (BIT 3-2-1-0) Bit04: AI1 voltage (V) Bit05: AI2 voltage (V) Bit06: Reserved Bit07: count value Hundreds place selection XXXXX (BIT 3-2-1-0) Bit08: length value Bit09: PLC stage Bit10: Load speed Bit11: PID setting Thousands place option XXXXX (BIT 3-2-1-0) Bit12: PULSE input pulse frequency (kHz)	03	☆

Par.	Designation	Scope	Default	Attr
P7-06	Load speed display factor	0.0001~6.5000	–	★
P7-07	Inverter module heat sink temperature	-20°C~120°C	–	●
P7-09	Cumulative running time	0h~65535h	–	●
P7-11	Feature version number	software version number	21	●
P7-12	Load speed display decimal places	Ones place: the number of decimal points for U0-14 0: 0 decimal places 1: 1 decimal place 2: 2 decimal places 3: 3 decimal places Tens place: U0-19/U0-29 decimal point 1: 1 decimal place 2: 2 decimal places	0.0s	☆
P7-13	Cumulative power-on time	0~65535h	–	●
P7-14	Cumulative power consumption	0~65535 degrees	–	●
Group P8 Auxiliary setting of operating frequency				
P8-00	Jog FREQ	0.00Hz~upper limit FREQ	2.00Hz	☆
P8-01	Jog Accel time	0.0s~6500.0s	20.0s	☆
P8-02	Jog Decel time	0.0s~6500.0s	20.0s	☆
P8-03	Accel time 2	0.0s~6500.0s	Model dependent	☆
P8-04	Decel time 2	0.0s~6500.0s	Model dependent	☆
P8-05	Accel time 3	0.0s~6500.0s	Model dependent	☆
P8-06	Decel time 3	0.0s~6500.0s	Model dependent	☆
P8-07	Accel time 4	0.0s~6500.0s	Model dependent	☆
P8-08	Decel time 4	0.0s~6500.0s	Model dependent	☆
P8-09	Hop Frequency 1	0.00Hz~Maximum frequency	0.00Hz	☆
P8-10	Hop Frequency 2	0.00Hz~Maximum frequency	0.00Hz	☆

Chapter 5 Parameter Table

Par.	Designation	Scope	Default	Attr
P8-11	Hop Frequency Amplitude	0.00Hz~upper limit FREQ	0.00Hz	☆
P8-12	Forward and reverse dead time	0.0s~3000.0s	0.00Hz	☆
P8-13	Reverse frequency prohibited	0: invalid 1: Valid	0	☆
P8-14	The set frequency is lower than the lower limit frequency operation mode	0: Run at the lower frequency limit 1: Stop 2: Running at zero speed	0	☆
P8-15	Sag rate	0.00%~100.00%	0.00%	☆
P8-16	Set the cumulative power-on arrival time	0h~65000h	0h	☆
P8-17	Set the cumulative operation arrival time	0h~65000h	0h	☆
P8-18	Boot protection selection	0: No protection 1: Protection	0	☆
P8-19	Frequency detection value 1	0.00Hz~upper limit FREQ	50.00Hz	☆
P8-20	Frequency detection hysteresis 1	0.0%~100.0% (PDT1 level)	5.00%	☆
P8-21	Frequency arrival detection amplitude	0.0%~100.0% (maximum frequency)	0.00%	☆
P8-22	Whether the jump frequency is valid during acceleration and deceleration	0: invalid	0	☆
P8-25	Acceleration time 1 and acceleration time 2 switch frequency points	0.00Hz~Maximum frequency	0.00Hz	☆
P8-26	Deceleration time 1 and deceleration time 2 switch frequency points	0.00Hz~Maximum frequency	0.00Hz	☆
P8-27	Terminal jog priority	0: Invalid 1: Valid	0	☆
P8-28	Frequency detection value 2	0.00Hz~Maximum frequency	50.00Hz	☆

Par.	Designation	Scope	Default	Attr
P8-29	Frequency detection lag rate 2	0.0%~100.0% (PDT2 level)	5.00%	☆
P8-30	Arbitrary arrival frequency detection value 1	0.00Hz~Maximum frequency	50.00Hz	☆
P8-31	Arbitrary arrival frequency detection amplitude 1	0.0%~100.0% (maximum frequency)	0.00%	☆
P8-32	Arbitrary arrival frequency detection value 2	0.00Hz~Maximum frequency	50.00Hz	☆
P8-33	Arbitrary arrival frequency detection amplitude 2	0.0%~100.0% (maximum frequency)	0.00%	☆
P8-34	Zero current detection level	0.0%~300.0% 100.0% corresponds to the rated current of the motor	5.00%	☆
P8-35	Zero current detection delay time	0.01s~600.00s	0.10s	☆
P8-36	The output current exceeds the limit	0.0% (not detected) 0.1%~300.0% (motor rated current)	200.00%	☆
P8-37	Output current overrun detection delay time	0.01s~600.00s	0.00S	☆
P8-38	Arbitrary arrival current 1	0.0%~300.0% (motor rated current)	100.00%	☆
P8-39	Arbitrary arrival current 1 amplitude	0.0%~300.0% (motor rated current)	0.00%	☆
P8-40	Arbitrary arrival current 2	0.0%~300.0% (motor rated current)	100.00%	☆
P8-41	Arbitrary arrival current 2 amplitude	0.0%~300.0% (motor rated current)	0.00%	☆
P8-42	Timing function selection	0: Invalid 1: Valid	0	★
P8-43	Timing run time selection	0: P8-44 setting 1: Ai1 2: Ai2 Analog input range corresponds to P8-44	0.00Hz	★
P8-44	Timing run time	0.0Min~6500.0Min	0.0Min	★

Chapter 5 Parameter Table

Par.	Designation	Scope	Default	Attr
P8-45	Ai1 input voltage protection value lower limit	0.00V~P8-46	3.10V	☆
P8-46	Ai1 input voltage protection value upper limit	P8-45~10.00V	6.80V	☆
P8-47	Module temperature reached	0°C~100°C	90°C	☆
P8-48	Cooling Fan Control	0: Fan runs during operation 1: The fan keeps running	0	☆
P8-49	wake up frequency	Sleep frequency (P8-51)~Maximum frequency (A0-10)	0.00Hz	☆
P8-50	Wake up delay time	0.0s~6500.0s	0.0s	☆
P8-51	Sleep frequency	0.00Hz~Wake up frequency (P8-49)	0.00Hz	☆
P8-52	sleep delay time	0.0s~6500.0s	0.0s	☆
P8-53	Arrival time of this run	0.0~6500.0 minutes	0.0Min	☆
P8-54	Output power correction factor	0.00%0.00%~200.0%	100.00%	☆
Group P9 Protection Parameters				
P9-00	Motor overload protection selection	0: Disable 1: Allow	1	☆
P9-01	Motor overload protection gain	0.20~10.00	1	☆
P9-02	Motor overload warning factor	50%~100%	80%	☆
P9-03	Overvoltage Stall Gain	0~100	30	☆
P9-04	Overvoltage stall protection voltage	650V~800V	720V	☆
P9-07	Short-circuit protection selection to ground	One's place: power-on to ground short-circuit protection selection 0: invalid 1: Valid Tens place: selection of short-circuit protection to ground before running	1	☆

Par.	Designation	Scope	Default	Attr
		0: invalid 1: Valid		
P9-08	Braking unit action starting voltage	650V~800V	720V	★
P9-09	Fault automatic reset times	0~20	0	☆
P9-10	Fault DO action selection during fault automatic reset	0: No action 1: Action	0	☆
P9-11	Fault automatic reset waiting time	0.1s~100.0s	1.0s	☆
P9-12	Input phase loss\contactor pick-up protection selection	Ones place: input phase loss protection selection Ten digit: contactor pull-in protection selection 0: Disable 1: Allow	11	☆
P9-13	Output phase loss protection selection	Ones place: output phase loss protection selection 0: Disable 1: Allow Tens place: output phase loss protection selection before running 0: Disable 1: Allow	11	☆
P9-14	Type of first failure	0: No fault 1: Reserved 2: Acceleration overcurrent 3: Deceleration overcurrent 4: Constant speed overcurrent	-	●
P9-15	Second fault type	5: Acceleration overvoltage 6: Deceleration overvoltage 7: Constant speed overvoltage 8: Buffer power failure 9: Undervoltage	-	●

Par.	Designation	Scope	Default	Attr
P9-16	Third (most recent) failure type	10: Inverter overload 11: Motor overload 12: Input phase loss 13: Output phase loss 14: Module overheating 15: External fault 16: Communication abnormality 17: The contactor is abnormal 18: Abnormal current detection 19: Abnormal motor tuning 20: The encoder/PG card is abnormal 21: Parameter read and write exception 22: The inverter hardware is abnormal 23: Motor short circuit to ground 24: Reserved 25: Reserved 26: Runtime arrives 27: User-defined fault 1 28: User-defined fault 2 29: The power-on time arrives 30: Drop load 31: PID feedback lost during runtime 40: Fast current limit timeout 41: Switch the motor while running 42: The speed deviation is too large 43: Motor overspeed 45: Motor over temperature 51: Initial position error 55: Slave fault during master-slave control	-	●

Par.	Designation	Scope	Default	Attr
P9-17	Frequency at the third (most recent) failure	-	-	●
P9-18	Current at the third (most recent) fault	-	-	●
P9-19	Bus voltage at the third (most recent) fault	-	-	●
P9-20	Input terminal status at the third (last) fault	-	-	●
P9-21	Output terminal status at the third (latest) fault	-	-	●
P9-22	Inverter status at the third (last) fault	-	-	●
P9-23	Power-on time at the third (most recent) fault	-	-	●
P9-24	Uptime on third (most recent) failure	-	-	●
P9-27	Frequency at second failure	-	-	●
P9-28	Current at the second fault	-	-	●
P9-29	Bus voltage at the second fault	-	-	●
P9-30	Input terminal status at the second fault	-	-	●
P9-31	Output terminal status at the second fault	-	-	●
P9-32	Inverter status at the second fault	-	-	●
P9-33	Power-on time at the second fault	-	-	●
P9-34	Operating time at second failure	-	-	●
P9-37	Frequency at first failure	-	-	●
P9-38	Current at first fault	-	-	●
P9-39	Bus voltage at first fault	-	-	●
P9-40	Input terminal status at the first fault	-	-	●

Par.	Designation	Scope	Default	Attr
P9-41	Output terminal status at the first fault	-	-	●
P9-42	Inverter status at first fault	-	-	●
P9-43	Power-on time at first fault	-	-	●
P9-44	Uptime at first failure	-	-	●
P9-47	Fault protection action selection 1	Units place: Motor overload 0: Free parking 1: stop according to the stop mode 2: keep running Tens place: input phase loss Hundreds place: output phase loss Thousands: External fault Ten thousand: abnormal communication	0	☆
P9-48	Fault protection action selection 2	Ones place: Encoder/PG card abnormal 0: Free parking Tens place: abnormal reading and writing of function code 0: Free parking 1: stop according to the stop mode Hundreds place: Inverter overload fault action selection 0: Free stop 1: Derating operation Thousands: Motor overheated Ten thousand: the running time arrives	0	☆
P9-49	Fault protection action selection 3	Ones place: User-defined fault 1 0: Free parking 1: stop according to the stop mode 2: keep running Tens place: User-defined fault 2 0: Free parking 1: stop according to the stop mode	0	☆

Par.	Designation	Scope	Default	Attr
P9-49	Fault protection action selection 3	2: keep running Hundreds place: the power-on time arrives 0: Free parking 1: stop according to the stop mode 2: keep running Thousands: drop load 0: Free parking 1: Decelerate to stop 2: Jump directly to 7% of the rated frequency of the motor and continue to run, when the load is not dropped Automatic recovery to set frequency operation Ten thousand: PID feedback lost during running 0: Free parking 1: stop according to the stop mode 2: keep running	0	☆
P9-50	Fault protection action selection 4	Ones place: Speed deviation is too large 0: Free parking 1: stop according to the stop mode 2: keep running Tens place: Motor overspeed Hundreds place: wrong initial position	-	☆
P9-54	Continue to run frequency selection in case of failure	0: Run at the current operating frequency 1: Run at the set frequency 2: Run at the upper limit frequency 3: Run at the lower frequency limit 4: Running at abnormal standby frequency	-	☆
P9-55	Second Frequency Converter Status	0.0%~100.0% (100.0% corresponds to the maximum frequency A0-10)	100.00%	☆

Chapter 5 Parameter Table

Par.	Designation	Scope	Default	Attr
P9-56	Second power-on time	0: No temperature sensor 1: Pt100 2: Pt1000	0	☆
P9-57	Second run time	0°C~200°C	110°C	☆
P9-58	Frequency at first failure	0°C~200°C	90°C	☆
P9-59	Current at first fault	0: Invalid 1: Bus voltage constant control 2: Decelerate to stop	0	★
P9-60	Instantaneous power failure and non-stop recovery of voltage	80%~100%	85%	★
P9-61	Instantaneous power failure and non-stop voltage recovery judgment time	0.0~100.0s	0.5s	★
P9-62	Instantaneous stop and non-stop action voltage	60%~100%	80%	★
P9-63	Drop load protection option	0: invalid 1: Valid	0	☆
P9-64	Load drop detection level	0.0~100.0%	10.00%	☆
P9-65	Load drop detection time	0.0~60.0s	1.0S	☆
P9-67	Overspeed detection value	0.0%~50.0% (maximum frequency)	20.00%	☆
P9-68	Overspeed detection time	0.0s: no detection 0.1~60.0s	1.0S	☆
P9-69	Excessive speed deviation detection value	0.0%~50.0% (maximum frequency)	20.00%	☆
P9-70	Excessive speed deviation detection time	0.0s: no detection 0.1~60.0s	5.0S	☆
P9-71	Instantaneous stop non-stop gain Kp	0~100	40	☆
P9-72	Instantaneous stop and non-stop integral coefficient Ki	0~100	30	☆
P9-73	Instantaneous stop non-stop action deceleration time	0~300.0s	20.0S	★

Par.	Designation	Scope	Default	Attr
Group PA Process PID				
PA-00	PID setting	0: PA-01 setting 1: Ai1 2: Ai2 3: Panel potentiometer 4: Pulse setting (X6) 5: Communication given 6: Multi-segment instruction given	0	☆
PA-01	PID digital setting	0.0%~100.0%	50.0%	☆
PA-02	PID feedback	0: Ai1 1: Ai2 2: Panel potentiometer 3: AI1-AI2 4: Pulse setting (X6) 5: Communication given 6: AI1+AI2 7: MAX(AI1 , AI2) 8: MIN(AI1 , AI2)	0	☆
PA-03	PID action direction	0: Positive action 1: Reverse action	0	☆
PA-04	PID given feedback range	0~65535	1000	☆
PA-05	Proportional gain Kp1	0.0~1000.0	50.0	☆
PA-06	Integration time Ti1	0.01s~10.00s	2.00s	☆
PA-07	Derivative time Td1	0.000s~10.000s	0.000s	☆
PA-08	Cutoff FREQ when opposite to rotary set direction	0.00Hz~maximum FREQ	0.00Hz	★
PA-09	PID offset limit	0.0%~100.0%	0.0%	☆
PA-10	PID derivative limit	0.0%~100.0%	0.10%	☆
PA-11	Filtering time of PID setting	0.00~650.00s	0.00s	☆
PA-12	Filtering time of PID feedback	0.00s~60.00s	0.00s	☆
PA-13	Filtering time of PID output	0.00s~60.00s	0.00s	☆

Chapter 5 Parameter Table

Par.	Designation	Scope	Default	Attr
PA-14	Reserved	-	-	-
PA-15	Proportional gain Kp2	0.0~1000.0	20	☆
PA-16	Integration time Ti2	0.01s~10.00s	2.00s	☆
PA-17	Derivative time Td2	0.000s~10.000s	0.000s	☆
PA-18	PID parameter switch	0: Do not switch 1: Switch through the X terminal 2: Automatically switch according to the deviation 3: Automatically switch according to the operating frequency	0	☆
PA-19	PID parameter switching deviation 1	0.0%~PA-20	20.0%	☆
PA-20	PID parameter switching deviation 2	PA-19~100.0%	80.0%	☆
PA-21	PID initial value	0.0%~100.0%	0.0%	☆
PA-22	PID initial value holding time	0.00~650.00s	0.0s	☆
PA-23	Reserve	-	-	-
PA-24	Reserve	-	-	-
PA-25	PID integral properties	Units: Integral separation 0: invalid 1: Valid Tens place: whether to stop integration after the output reaches the limit value 0: Continue points 1: Stop integration	0	☆
PA-26	PID feedback loss detection value	0.0%: Not judged feedback loss 0.1%~100.0%	0.0%	☆
PA-27	PID feedback loss detection time	0.0s~20.0s	0.0s	☆
PA-28	PID shutdown operation	0: Stop and do not operate 1: Compute at stop	0	☆

Par.	Designation	Scope	Default	Attr
Group PB: Fixed length counting parameter				
PB-05	Set length	0m~65535m	1000m	☆
PB-06	Actual length	0m~65535m	0m	☆
PB-07	Pulses per meter	0.1~6553.5	100	☆
PB-08	Set count value	1~65535	1000	☆
PB-09	Specify count value	1~65535	1000	☆
Group PC Multi-segment instructions, simple PLC				
PC-00	Multiband frequency 0	-100.0%~100.0%	0.00%	☆
PC-01	Multiband frequency 1	-100.0%~100.0%	0.00%	☆
PC-02	Multiband frequency 2	-100.0%~100.0%	0.00%	☆
PC-03	Multiband frequency 3	-100.0%~100.0%	0.00%	☆
PC-04	Multiband frequency 4	-100.0%~100.0%	0.00%	☆
PC-05	Multiband frequency 5	-100.0%~100.0%	0.00%	☆
PC-06	Multiband frequency 6	-100.0%~100.0%	0.00%	☆
PC-07	Multiband frequency 7	-100.0%~100.0%	0.00%	☆
PC-08	Multiband frequency 8	-100.0%~100.0%	0.00%	☆
PC-09	Multiband frequency 9	-100.0%~100.0%	0.00%	☆
PC-10	Multiband frequency 10	-100.0%~100.0%	0.00%	☆
PC-11	Multiband frequency 11	-100.0%~100.0%	0.00%	☆
PC-12	Multiband frequency 12	-100.0%~100.0%	0.00%	☆
PC-13	Multiband frequency 13	-100.0%~100.0%	0.00%	☆
PC-14	Multiband frequency 14	-100.0%~100.0%	0.00%	☆
PC-15	Multiband frequency 15	-100.0%~100.0%	0.00%	☆
PC-16	Simple PLC operation mode	0: Stop at the end of a single operation 1: Keep the final value at the end of a single run 2: keep looping	0	☆

Chapter 5 Parameter Table

Par.	Designation	Scope	Default	Attr
PC-17	Simple PLC power-down memory selection	Ones place: power-down memory selection 0: no memory when power off Tens place: stop memory selection 0: no memory when stopped 1: Power-down memory 2: Stop memory	0	☆
PC-18	Simple PLC section 0 running time	0.0s(h)~6553.5s(h)	0.0s(h)	☆
PC-19	Simple PLC section 0 acceleration and deceleration time selection	0~3	0	☆
PC-20	Simple PLC section 1 running time	0.0s(h)~6553.5s(h)	0.0s(h)	☆
PC-21	Simple PLC section 1 acceleration and deceleration time selection	0~3	0	☆
PC-22	Simple PLC section 2 running time	0.0s(h)~6553.5s(h)	0.0s(h)	☆
PC-23	Simple PLC section 2 acceleration and deceleration time selection	0~3	0	☆
PC-24	Simple PLC section 3 running time	0.0s(h)~6553.5s(h)	0.0s(h)	☆
PC-25	Simple PLC section 3 acceleration and deceleration time selection	0~3	0	☆
PC-26	Simple PLC section 4 running time	0.0s(h)~6553.5s(h)	0.0s(h)	☆
PC-27	Simple PLC section 4 acceleration and deceleration time selection	0~3	0	☆
PC-28	Simple PLC section 5 running time	0.0s(h)~6553.5s(h)	0.0s(h)	☆
PC-29	Simple PLC section 5 acceleration and deceleration time selection	0~3	0	☆
PC-30	Simple PLC section 6 running time	0.0s(h)~6553.5s(h)	0.0s(h)	☆
PC-31	Simple PLC section 6 acceleration and deceleration time selection	0~3	0	☆
PC-32	Simple PLC section 7 running time	0.0s(h)~6553.5s(h)	0.0s(h)	☆
PC-33	Simple PLC section 7 acceleration and deceleration time selection	0~3	0	☆

Par.	Designation	Scope	Default	Attr
PC-34	Simple PLC section 8 running time	0.0s(h)~6553.5s(h)	0.0s(h)	☆
PC-35	Simple PLC section 8 acceleration and deceleration time selection	0~3	0	☆
PC-36	Simple PLC section 9 running time	0.0s(h)~6553.5s(h)	0.0s(h)	☆
PC-37	Simple PLC section 9 acceleration and deceleration time selection	0~3	0	☆
PC-38	Simple PLC section 10 running time	0.0s(h)~6553.5s(h)	0.0s(h)	☆
PC-39	Simple PLC section 10 acceleration and deceleration time selection	0~3	0	☆
PC-40	Simple PLC section 11 running time	0.0s(h)~6553.5s(h)	0.0s(h)	☆
PC-41	Simple PLC section 11 acceleration and deceleration time selection	0~3	0	☆
PC-42	Simple PLC section 12 running time	0.0s(h)~6553.5s(h)	0.0s(h)	☆
PC-43	Simple PLC section 12 acceleration and deceleration time selection	0~3	0	☆
PC-44	Simple PLC section 13 running time	0.0s(h)~6553.5s(h)	0.0s(h)	☆
PC-45	Simple PLC section 13 acceleration and deceleration time selection	0~3	0	☆
PC-46	Simple PLC section 14 running time	0.0s(h)~6553.5s(h)	0.0s(h)	☆
PC-47	Simple PLC section 14 acceleration and deceleration time selection	0~3	0	☆
PC-48	Simple PLC section 15 running time	0.0s(h)~6553.5s(h)	0.0s(h)	☆
PC-49	Simple PLC section 15 acceleration and deceleration time selection	0~3	0	☆
PC-50	Simple PLC running time unit	0: s (seconds) 1: h (hours)	0	☆
PC-51	Simple PLC running time unit	0: Function code PC-00 given 1: Ai1 2: Ai2 3: Panel potentiometer 4: Pulse 5: PID	0	☆

Par.	Designation	Scope	Default	Attr
PC-51	Simple PLC running time unit	6: Preset frequency (A0-08) given, UP/DOWN can be modified	0	☆
Group PD MODBUS Communication Parameters				
PD-00	Communication baud rate	Ones place: MODBUS 0: 300BPS 1: 600BPS 2: 1200BPS 3: 2400BPS 4: 4800BPS 5: 9600BPS 6: 19200BPS 7: 38400BPS 8: 57600BPS 9: 115200BPS Ten: reserved Hundreds: reserved Thousands: reserved	5	☆
PD-01	MODBUS data format	0: No checksum (8-N-2) 1: Even parity (8-E-1) 2: Odd parity (8-O-1) 3: No checksum (8-N-1)	1	☆
PD-02	Local address	0: broadcast address 1~247	1	☆
PD-03	MODBUS response delay	0~20ms	2	☆
PD-04	Serial communication timeout time	0.0: invalid 0.1~60.0s	0	☆
PD-05	Communication data format	Ones place: MODBUS 0: Non-standard MODBUS protocol 1: Standard MODBUS protocol	30	☆
PD-06	Communication read current resolution	0: 0.01A (effective when $\leq 55\text{kW}$) 1: 0.1A	0	☆
Group PP Function code management				
PP-00	User password	0~65535	0	☆

Par.	Designation	Scope	Default	Attr
PP-01	Parameter initialization	0: No operation 01: Restore factory parameters, excluding motor parameters 02: Clear record information 04: Backup user's current parameters 05: Restore user backup parameters	0	★
PP-02	Function parameter group display selection	Ones place: U group display selection 0: not displayed 1: Display Tens place: P group display selection 0: not displayed 1: Display	11	☆
PP-03	Personality parameter group display selection	Units place: User-defined parameter group display selection 0: not displayed 1: Display Tens digit: User changes parameter group display selection 0: not displayed 1: Display	0	☆
PP-04	Function code modification attribute	0: Modifiable 1: Cannot be modified	0	☆
Group A0: Torque Control Parameters				
A0-00	Speed/torque control mode selection	0: Speed control 1: Torque control	0	★
A0-01	Torque setting selection in torque control mode	0: Digital setting 1 (A0-03) 1: Ai1 2: Ai2 3: Panel potentiometer 4: PULSE pulse 5: Communication given 6: MIN (Ai1, Ai2) 7: MAX (Ai1, Ai2) (The full scale of options 1-7 corresponds to the digital setting of A0-03)	0	★
A0-03	Torque digital setting in torque control mode	-200.0%~200.0%	150.00%	☆

Chapter 5 Parameter Table

Par.	Designation	Scope	Default	Attr
A0-05	Torque control forward maximum frequency	0.00Hz~Maximum frequency	50.00Hz	☆
A0-06	Torque control reverse maximum frequency	0.00Hz~Maximum frequency	50.00Hz	☆
A0-07	Torque rise filter time	0.00s~65000s	0.00s	☆
A0-08	Torque drop filter time	0.00s~65000s	0.00s	☆
Group A5: Control optimization parameters				
A5-00	DPWM switching upper limit frequency	5.00Hz~Maximum frequency	8.00Hz	☆
A5-01	PWM modulation method	0: Asynchronous modulation 1: Synchronous modulation	0	☆
A5-02	Dead time compensation mode selection	0: no compensation 1: Compensation mode 1	1	☆
A5-03	Random PWM depth	0: Random PWM is invalid 1~10: PWM carrier frequency random depth	0	☆
A5-04	Fast current limit enable	0: Disable 1: enable	1	☆
A5-05	Maximum output voltage coefficient	100~110%	105%	★
A5-06	Undervoltage point setting	210~420V	350V	☆
A5-08	low speed carrier	0.0~8.0kHz	0	☆
A5-09	Overvoltage point setting	200.0V~2500.0V	Model dependent	★
A5-11	Low speed DC braking threshold	0.00~5.00Hz	0.30Hz	☆
Group U0: Basic monitoring parameters				
U0-00	Operating frequency (Hz)	0.01Hz	7000H	
U0-01	Set frequency (Hz)	0.01Hz	7001H	
U0-02	Bus voltage (V)	0.1V	7002H	
U0-03	Output voltage (V)	1V	7003H	
U0-04	Output current (A)	0.01A	7004H	
U0-05	Output torque (%)	0.1kW	7005H	

Par.	Designation	Scope	Default	Attr
U0-06	Output torque (%)	0.001	7006H	
U0-07	X input state	1	7007H	
U0-08	DO output status	1	7008H	
U0-09	Ai1 Voltage (V)	0.01V	7009H	
U0-10	Ai2 voltage (V)/current (mA)	0.01V/0.01mA	700AH	
U0-12	Count value	1	700CH	
U0-13	length value	1	700DH	
U0-14	Load speed display	1	700EH	
U0-15	PID setting	1	700FH	
U0-16	PID feedback	1	7010H	
U0-17	PLC stage	1	7011H	
U0-18	Input pulse frequency (Hz)	0.01kHz	7012H	
U0-19	Feedback speed (Hz)	0.01Hz	7013H	
U0-20	remaining running time	0.1Min	7014H	
U0-21	Ai1 voltage before correction	0.001V	7015H	
U0-22	Ai2 Voltage (V)/Current (mA) before calibration	0.001V/0.01mA	7016H	
U0-24	Line speed	1m/Min	7018H	
U0-25	Current power-on time	1Min	7019H	
U0-26	current running time	0.1Min	701AH	
U0-27	input pulse frequency	1Hz	701BH	
U0-28	Communication settings	0.0001	701CH	
U0-30	main frequency display	0.01Hz	701EH	
U0-31	Auxiliary frequency display	0.01Hz	701FH	
U0-32	View arbitrary memory address value	1	7020H	
U0-34	Motor temperature value	1°C	7022H	
U0-39	V/F separation target voltage	1V	7027H	

Chapter 5 Parameter Table

Par.	Designation	Scope	Default	Attr
U0-40	V/F split output voltage	1V	7028H	
U0-41	Intuitive display of X input status	1.00	7029H	
U0-42	Intuitive display of Do output status	1.00	702AH	
U0-43	X function status visual display 1 (function 01-40)	1.00	702BH	
U0-44	X function status visual display 2 (functions 41-80)	1.00	702CH	
U0-45	accident details	1.00	702DH	
U0-59	Set frequency (%)	0.00	703BH	
U0-60	Running frequency (%)	0.00	703CH	
U0-61	Inverter status	1.00	703DH	
U0-62	Current fault code	1.00	703EH	



Chapter 6

Detailed function description

Group P0: Basic function group

Function code	Name	Description (setting range)	Factory Default	Change
P0-00	GP type display	1~2	1	●

This parameter is only for users to check the factory model.

- 1: Suitable for constant torque loads with specified rated parameters
- 2: Suitable for variable torque loads with specified rated parameters (fan, water pump loads)

Function code	Name	Description (setting range)	Factory Default	Change
P0-01	1st motor control method	0~2	2	★

0: Open loop vector control

Refers to open-loop vector control, which is suitable for general high-performance control occasions. One inverter can only drive one motor.

1: Closed-loop vector control

Refers to closed-loop vector control, an encoder must be installed at the motor end, and the inverter must be equipped with a PG card of the same type as the encoder. It is suitable for high-precision speed control or torque control.

2: V/F control

It is suitable for occasions where the load requirements are not high, or where one inverter drives multiple motors, such as fans and pumps. Prompt: The motor parameter identification process must be carried out when the vector control mode is selected. Only accurate motor parameters can take advantage of the vector control mode. Better performance can be obtained by adjusting the function code of the speed regulator parameter P2 group.

Function code	Name	Description (setting range)	Factory Default	Change
P0-02	Run command selection	0~2	3	☆

Select the input channel of the inverter running command.

- 0: The running command is controlled by the RUN, STOP/RES keys on the keyboard.
- 1: The running command is controlled by the multi-function input terminals FWD, REV, JOGF, JOGR, etc.
- 2: The running command is given by the upper computer through communication. When this option is selected, a communication card (ModbusRTU, CANopen card, etc.) must be selected.

Function code	Name	Description (setting range)	Factory Default	Change
P0-03	Master FREQ set	1~2	4	★

0: Keyboard digital setting (no memory when power off)

The initial value of the set frequency is the value of P0-08. The set frequency value of the inverter can be changed through the ▲ and ▼ keys of the keyboard (or the UP and DOWN of the multi-function input terminal).

When the inverter is powered off and powered on again, the set frequency value returns to the value of P0-08.

1: Keyboard digital setting (power-down memory)

The initial value of the set frequency is the value of P0-08. The set frequency value of the inverter can be changed through the keys ▲ and ▼ on the keyboard (or UP and DOWN of the multi-function input terminal).

When the inverter is powered off and powered on again, the set frequency is the set frequency at the time of the last power off, and the correction value of the ▲ and ▼ keys on the keyboard or the terminals UP and DOWN is memorized.

It should be reminded that P0-23 is "digital setting frequency stop memory selection", P0-23 is used to select whether the frequency correction amount is memorized or cleared when the inverter stops. P0-23 is related to shutdown, not to power-off memory, so pay attention in application.

2: AI1

3: AI2

It means that the frequency is determined by the analog input terminal. The control board provides 2 analog input terminals (AI1, AI2).

in:

AI1 is 0V~10V voltage input;

AI2 can be 0V~10V voltage input, or 4mA~20mA current input, which is selected by the J8 jumper on the control board;

The user can freely choose the corresponding relationship between the input voltage value of AI1 and AI2 and the target frequency. The inverter provides 5 sets of corresponding relationship curves, of which 3 sets of curves are straight-line relationships (2-point correspondence), and 2 sets of curves are arbitrary curves with 4-point correspondences, which can be set by the user through the P4 and A6 function codes.

Function code P4-33 is used to set the two analog inputs of AI1~AI2, and select which of the 5 sets of curves respectively. For the specific corresponding relationship of the 5 curves, please refer to the description of the function codes of the P4 and A6 groups.

5: Pulse given (DI5)

The frequency given is given by the terminal pulse. Pulse given signal specifications: voltage range 9V ~ 30V, frequency range 0kHz ~ 100kHz. Pulse given can only be input from multi-function input terminal DI5. The relationship between the input pulse frequency of the DI5 terminal and the corresponding setting is set through P4-28~P4-31. The corresponding relationship is a straight line corresponding relationship between 2 points. The 100.0% set corresponding to the pulse input refers to the relative maximum frequency P0 -10 percent.

6: Multi-segment instruction

When selecting multi-segment command operation mode, it is necessary to input different state combinations of DI terminals through digital input to correspond to different set frequency values. The inverter can set 4 multi-segment command terminals, 16 states of the 4 terminals, which can correspond to any 16 "multi-segment commands" through the PC group function code, and the "multi-segment command" is the percentage relative to the maximum frequency P0-10.

When the digital input DI terminal is used as the multi-segment command terminal function, it needs to be set in the P4 group. For details, please refer to the related function parameter description of the P4 group.

7: The program runs

When the frequency is set to program running, the running frequency of the inverter can be switched between 1 to 16 arbitrary frequency commands, and the holding time and the respective acceleration and deceleration time of 1 to 16 frequency commands can also be set by the user. For details, please refer to the relevant description of the PC group.

8: PID

Select the output of the process PID control as the operating frequency.

9: Communication given

It means that the main channel of frequency setting is given by the host computer through communication.

Function code	Name	Description (setting range)	Factory Default	Change
P0-04	Auxiliary frequency source input selection	Same as P0-03	0	★

When the frequency of the auxiliary channel is used as an independent frequency reference channel (that is, the frequency setting is selected as X to Y switching), its usage is the same as that of the frequency setting main channel X. For the usage method, please refer to the relevant instructions of P0-03.

When the frequency of the auxiliary channel is used for superposition (that is, the frequency setting is selected as X+Y, X to X+Y switching or Y to X+Y switching), it is necessary to pay attention to:

1. When the auxiliary channel is digital given:

P0-08 does not work, the frequency adjustment performed by the user through the ▲ and ▼ keys of the keyboard (or the UP and DOWN of the multi-function input terminal) is directly adjusted on the basis of the main given frequency.

2. When the auxiliary channel is given by analog input (AI1,AI2) or given by pulse input:

The input given 100% corresponds to the auxiliary frequency setting range, which can be set through P0-05 and P0-06.

3. When the auxiliary channel is pulse input given:

Similar to analog given.

Function code	Name	Description (setting range)	Factory Default	Change
P0-05	Auxiliary frequency command range selection	0~1	1	☆
P0-06	Frequency auxiliary given coefficient	0%~150%	100%	☆

When the combination mode of the main and auxiliary channels is selected as "main and auxiliary operation" (that is, P0-07 is set to 1, 3 or 4), these two parameters are used to determine the adjustment range of the auxiliary channels.

P0-05 is used to determine the object corresponding to the auxiliary channel range. It can be selected relative to the maximum frequency or relative to the main channel X. If it is selected to be relative to the main channel, the range of the auxiliary channel will change with the frequency of the main channel. and change.

Function code	Name	Description (setting range)	Factory Default	Change
P0-07	Main and auxiliary frequency superposition selection	Ones place: 0~4 Tens place: 0~3	0	☆

Use this parameter to select the frequency given channel. Frequency setting is realized by the combination of frequency setting main channel X and auxiliary frequency setting Y. Ones place: Frequency setting selection:

0: Main channel X

Main channel X as the target frequency.

1: Main and auxiliary operation results

The main and auxiliary operation results are used as the target frequency, and the relationship between the main and auxiliary operations is shown in the "tens" description of this function code.

2: Switch between main channel X and auxiliary channel Y

When the multi-function input terminal function 18 (frequency switching) is invalid, the main channel X is used as the target frequency.

When the multi-function input terminal function 18 (frequency setting switching) is valid, the auxiliary channel Y is used as the target frequency.

3: Switch between the main channel X and the main and auxiliary operation results

When the multi-function input terminal function 18 (frequency switching) is invalid, the main channel X is used as the target frequency.

When the multi-function input terminal function 18 (frequency switching) is valid, the main and auxiliary operation results are used as the target frequency.

4: Switch between auxiliary channel Y and main and auxiliary operation results

When the multi-function input terminal function 18 (frequency switching) is invalid, the auxiliary channel Y is used as the target frequency.

When the multi-function input terminal function 18 (frequency switching) is valid, the main and auxiliary operation results are used as the target frequency. Tens place: Frequency setting main and auxiliary operation relationship:

0: main channel X + auxiliary channel Y

The sum of the main channel X and the auxiliary channel Y is used as the target frequency. Realize the frequency superposition given function.

1: main channel X-auxiliary channel Y

The difference between the main channel X and the auxiliary channel Y is used as the target frequency.

2: MAX (main channel X, auxiliary channel Y)

Take the largest absolute value of the main channel X and the auxiliary channel Y as the target frequency.

3: MIN (main channel X, auxiliary channel Y)

Take the smallest absolute value of the main channel X and the auxiliary channel Y as the target frequency.

In addition, when the frequency setting is selected as the main and auxiliary operation, the offset frequency can be set through P0-21, and the offset frequency is superimposed on the main and auxiliary operation results to flexibly respond to various needs.

Function code	Name	Description (setting range)	Factory Default	Change
P0-08	Digital frequency setting	0.00Hz ~ Maximum frequency (A0-10)	50.00Hz	☆

When the frequency setting is selected as "digital setting" or "terminal UP/DOWN", the function code value is the frequency digital setting initial value of the inverter.

Function code	Name	Description (setting range)	Factory Default	Change
P0-09	Run direction	0~1	0	☆

By changing this function code, the purpose of changing the direction of the motor can be achieved without changing the wiring of the motor. Its function is equivalent to adjusting any two lines of the motor (U, V, W) to realize the conversion of the rotation direction of the motor.

Function code	Name	Description (setting range)	Factory Default	Change
P0-10	Maximum FREQ	Upper limit FREQ ~500.00Hz	50.00Hz	★

When the analog input is used as the frequency setting, the respective 100.0% are scaled relative to P0-10.

The maximum output frequency can reach 3200Hz. In order to take into account the two indicators of frequency command resolution and frequency input range, the number of decimal points of frequency command can be selected through P0-22.

When P0-22 is selected as 1, the frequency resolution is 0.1Hz, and the setting range of P0-10 is 50.0Hz ~ 3200.0Hz;

When P0-22 is selected as 2, the frequency resolution is 0.01Hz, and the setting range of P0-10 is 50.00Hz ~ 500.00Hz.

Function code	Name	Description (setting range)	Factory Default	Change
P0-11	Upper limit frequency command selection	0 ~5	0	★

Defines the upper limit frequency setting. The upper limit frequency can come from the digital setting (P0-12) or from the analog input channel. When using the analog input to set the upper limit frequency, 100% of the analog input setting corresponds to P0-12.

Function code	Name	Description (setting range)	Factory Default	Change
P0-12	Upper limit FREQ	Lower limit frequency A0-14~Maximum frequency A0-10	50.00Hz	☆
P0-13	Upper limit frequency offset	0.00Hz~Maximum frequency A0-10	0.00Hz	☆

Defines the upper limit frequency setting. The upper limit frequency can come from the digital setting (P0-12) or from the analog input channel. When using the analog input to set the upper limit frequency, 100% of the analog input setting corresponds to P0-12.

Function code	Name	Description (setting range)	Factory Default	Change
P0-14	Lower limit FREQ	0.00Hz~upper limit FREQ	0.00Hz	☆

When the frequency command is lower than the lower limit frequency set by P0-14, the inverter can stop, run at the lower limit frequency or run at zero speed, which operating mode can be selected by P8-14 (the set frequency is lower than the lower limit frequency operation mode) set up.

Function code	Name	Description (setting range)	Factory Default	Change
P0-15	Switching FREQ	0.5kHz~16.0kHz, factory default	Model dependent	☆

This function adjusts the carrier frequency of the inverter. By adjusting the carrier frequency, the motor noise can be reduced, the resonance point of the mechanical system can be -the line-to-ground leakage current can be reduced, and the interference generated by the inverter can be reduced.

When the carrier frequency is low, the higher harmonic components of the output current increase, the loss of the motor increases, and the temperature rise of the motor increases.

When the carrier frequency is high, the motor loss decreases and the motor temperature rise decreases, but the inverter loss increases, the inverter temperature rise increases, and the interference increases.

Function code	Name	Description (setting range)	Factory Default	Change
P0-16	The carrier frequency is adjusted with the size of the load	0~1	1	☆

The carrier frequency is adjusted with the temperature, which means that when the inverter detects that the temperature of its own radiator is high, it automatically reduces the carrier frequency to reduce the temperature rise of the inverter. When the radiator temperature is low, the carrier frequency gradually recovers to the set value. This function can reduce the chance of inverter overheating alarm.

Function code	Name	Description (setting range)	Factory Default	Change
P0-17	Accel time 1	0.0~65000	Model dependent	☆
P0-18	Decel time 1	0.0~65000	Model dependent	☆

Acceleration time refers to the time required for the inverter to accelerate from zero frequency to the reference frequency of acceleration and deceleration (determined by P0-25), as shown in the set acceleration time in Figure 6-1.

Deceleration time refers to the time required for the inverter to decelerate from the reference frequency of acceleration and deceleration (determined by P0-25) to zero frequency, as shown in the set deceleration time in Figure 6-1.

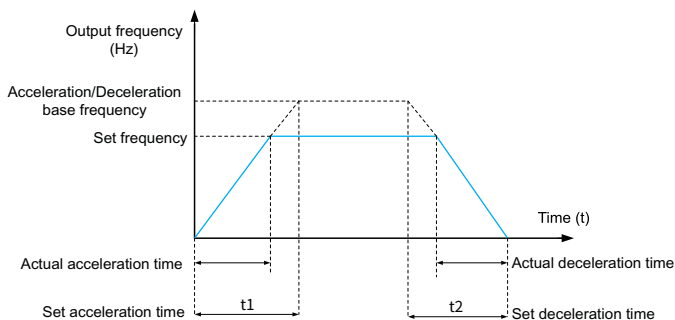

Fig.6-1 Schematic diagram of acceleration and deceleration time

Function code	Name	Description (setting range)	Factory Default	Change
P0-19	Accel/Decel time resolution	0~2	1	★

In order to meet the needs of various fields, the product provides 3 acceleration and deceleration time units, namely 1 second, 0.1 second and 0.01 second.

Note:

When modifying this function parameter, the number of decimal points displayed by the 4 groups of acceleration and deceleration time will change, and the corresponding acceleration and deceleration time will also change. Special attention should be paid during the application process.

Function code	Name	Description (setting range)	Factory Default	Change
P0-21	Auxiliary frequency command offset frequency when superimposed	0.00Hz~Maximum frequency A0-10	0.00Hz	☆

This function code is only valid when the frequency setting is selected as main and auxiliary operation.

When the frequency is set as the main and auxiliary operation, P0-21 is used as the bias frequency, and superimposed with the main and auxiliary operation results as the final frequency setting value, so that the frequency setting can be more flexible.

Function code	Name	Description (setting range)	Factory Default	Change
P0-23	Digital setting frequency stop memory selection	0~1	0	☆

This function is valid only when the frequency is set to digital.

"No memory" means that after the inverter stops, the digital set frequency value returns to the value of P0-08 (keyboard digital set frequency), and the frequency correction performed by the ▲ and ▼ keys on the keyboard or the terminals UP and DOWN is cleared.

"Memory" means that after the inverter is stopped, the digital set frequency remains the set frequency at the last stop time, and the frequency correction performed by the ▲ and ▼ keys on the keyboard or the terminals UP and DOWN remains valid.

Function code	Name	Description (setting range)	Factory Default	Change
P0-25	Acceleration and deceleration time reference frequency	0~1	0	★

The acceleration/deceleration time refers to the acceleration/deceleration time from zero frequency to the frequency set by P0-25. Figure 7-1 is a schematic diagram of the acceleration/deceleration time.

When P0-25 is selected as 1, the acceleration and deceleration time is related to the set frequency. If the set frequency changes frequently, the acceleration of the motor will change, so attention should be paid to the application.

Function code	Name	Description (setting range)	Factory Default	Change
P0-26	Frequency command UP/DOWN reference during operation	0~1	0	★

This parameter is only valid when the frequency is set to digital.

It is used to determine which method to use to correct the set frequency when the ▲ and ▼ keys of the keyboard or the terminal UP/DOWN act, that is, whether the target frequency increases or decreases on the basis of the running frequency, or increases or decreases on the basis of the set frequency.

The difference between the two settings is obvious when the inverter is in the process of acceleration and deceleration, that is, if the operating frequency of the inverter is different from the set frequency, the selection of this parameter is very different.

Function code	Name	Description (setting range)	Factory Default	Change
P0-26	Running command bundled main frequency command selection	0~9	0	☆

Three running command channels are defined to take precedence over nine frequency given channels to facilitate synchronous switching.

The meaning of the above frequency given channel is the same as the frequency setting main channel X selection P0-03, please refer to the description of P0-03 function code. Different running command channels can give priority to the same frequency given channel. When the running command has a priority frequency setting, the frequency setting set by P0-03~P0-07 will no longer work during the valid period of the running command.

Group P1: Motor Parameters

Function code	Name	Description (setting range)	Factory Default	Change
P1-00	Type of motor	0~1	0	★
P1-01	Power rating of motor	0.4kW~630kW	Model dependent	★
P1-02	Motor rated voltage	1V~1000V	Model dependent	★
P1-03	Motor rated current	0.01A~6553.5A	Model dependent	★
P1-04	Motor rated frequency	0.01Hz~upper limit frequency	Model dependent	★
P1-05	Rated speed of motor	1~65535r/min	Model dependent	★

The above function codes are the parameters of the motor nameplate, and the relevant parameters need to be set accurately according to the motor nameplate.

In order to obtain better vector control performance, self-learning of motor parameters is required, and the accuracy of adjustment results is closely related to the correct setting of motor nameplate parameters.

Function code	Name	Description (setting range)	Factory Default	Change
P1-06	Motor stator resistance	0.001Ω~65.535Ω (Inverter power ≤ 55kW) 0.0001Ω~6.5535Ω (Inverter power >55kW)	Self-learning parameters	★
P1-07	Motor rotor resistance	0.001Ω~65.535Ω (Inverter power ≤ 55kW) 0.0001Ω~6.5535Ω (Inverter power >55kW)	Self-learning parameters	★
P1-08	Motor leakage inductance	0.01mH~655.35mH (Inverter power ≤ 55kW) 0.001mH~65.535mH (Inverter power >55kW)	Self-learning parameters	★
P1-09	Motor mutual inductance	0.01mH~655.35mH (Inverter power ≤ 55kW) 0.001mH~65.535mH (Inverter power >55kW)	Self-learning parameters	☆

Function code	Name	Description (setting range)	Factory Default	Change
P1-10	Motor no-load current	0.01A~P1-03 (Inverter power ≤ 55kW) 0.1A~P1-03 (Inverter power >55kW)	Self-learning parameters	☆

P1-06~P1-10 are the parameters of the asynchronous motor, these parameters are generally not on the motor nameplate, and need to be obtained through the automatic self-learning of the inverter. Among them, "asynchronous motor static self-learning" can only obtain three parameters of P1-06~P1-08, and "asynchronous motor comprehensive self-learning" can obtain all the five parameters here, but also can obtain the encoder phase sequence, current Ring PI parameters, etc.

When changing the rated power of the motor (P1-01) or the rated voltage of the motor (P1-02), the inverter will automatically modify the parameter values of P1-06 to P1-10, and restore these five parameters to the commonly used standard Y series motor parameters.

If the induction motor cannot be self-learned on site, the above corresponding function codes can be input according to the parameters provided by the motor manufacturer.

Function code	Name	Description (setting range)	Factory Default	Change
P1-27	Number of encoder lines	1~65535	2500	★

Set the number of pulses per revolution of the ABZ or UVW incremental encoder.

In closed-loop vector control mode, the number of encoder pulses must be set correctly, otherwise the motor will not run normally.

Function code	Name	Description (setting range)	Factory Default	Change
P1-28	Encoder type	0~1	0	★

The product supports a variety of encoder types, and different encoders need to be equipped with different PG cards. Please purchase the PG card correctly when using it.

After installing the PG card, set P1-28 correctly according to the actual situation, otherwise the inverter may not operate normally.

Function code	Name	Description (setting range)	Factory Default	Change
P1-30	ABZ incremental encoder AB phase sequence	0~1	0	★

This function code is only valid for ABZ incremental encoder, that is, it is valid only when P1-28=0. Used to set the phase sequence of the AB signal of the ABZ incremental encoder.

When the asynchronous motor is fully self-learning, the AB phase sequence of the ABZ encoder can be obtained.

Function code	Name	Description (setting range)	Factory Default	Change
P1-34	Number of pole pairs of resolver	1~65535	1	★

The resolver has the number of pole pairs. When using this encoder, the parameter of the number of pole pairs must be set correctly.

Function code	Name	Description (setting range)	Factory Default	Change
P1-36	Speed feedback PG disconnection detection time	0.0s: no action 0.1s~10.0s	0.0s	★

It is used to set the detection time of the encoder disconnection fault. When it is set to 0.0s, the inverter will not detect the encoder disconnection fault.

When the inverter detects a disconnection fault, and the duration exceeds the time set by P1-36, the inverter alarms CPE.

Function code	Name	Description (setting range)	Factory Default	Change
P1-37	Tuning selection	0~3	0	★

0: No operation, that is, self-learning is prohibited.

1: The asynchronous machine is still self-learning.

It is suitable for occasions where the asynchronous motor and the load are not easy to be disconnected, and comprehensive self-learning cannot be performed. Before the asynchronous motor static self-learning, the motor type and the motor nameplate parameters P1-00~P1-05 must be set correctly. The asynchronous machine is static and self-learning, and the inverter can obtain three parameters from P1-06 to P1-08.

Action description: Set the function code to 1, then press the RUN key, the inverter will perform static self-learning.

2: The asynchronous machine is fully self-learning

In order to ensure the dynamic control performance of the inverter, please choose comprehensive self-learning. At this time, the motor must be disconnected from the load to keep the motor in a no-load state. During the comprehensive self-learning process, the inverter first performs static self-learning, and then accelerates to 80% of the rated frequency of the motor according to the acceleration time P0-17. After maintaining for a period of time, it decelerates and stops according to the deceleration time P0-18 and ends the self-learning.

Before the full self-learning of the asynchronous machine, in addition to the motor type and the motor nameplate parameters P1-00~P1-05, it is also necessary to correctly set the encoder type and encoder pulse number P1-27, P1-28.

The asynchronous machine is fully self-learning, and the inverter can obtain five motor parameters from P1-06 to P1-10, as well as the AB phase sequence of the encoder P1-30, and the vector control current loop PI parameters P2-13 to P2-16.

Action description: Set the function code to 2, and then press the RUN key, the inverter will conduct comprehensive self-learning.

During the no-load self-learning process, the inverter first completes the on-load self-learning, and then accelerates to P0-08 according to the acceleration time P0-17. After holding for a period of time, it decelerates to stop according to the deceleration time P0-18 and ends the self-learning. Note that P0-08 must be set to a value other than 0, otherwise the identification cannot be performed normally.

Note: Self-learning can only be performed in keyboard operation mode, not in terminal operation and communication operation mode Motor self-learning.

Group P2: Vector Control Parameters of Motor

Group P2 function codes are only valid for vector control.

Function code	Name	Description (setting range)	Factory Default	Change
P2-00	Speed loop low speed proportional gain	1~100	30	☆
P2-01	Speed loop low speed integration time	0.01s~10.00s	0.50s	☆
P2-02	Speed loop low-speed switching frequency	0.00~P2-05	5.00Hz	☆
P2-03	Speed loop high speed proportional gain	1~100	20	☆
P2-04	Speed loop high-speed integration time	0.01s~10.00s	1.00s	☆
P2-05	Speed loop high-speed switching frequency	P2-02~Maximum frequency	10.00Hz	☆

When the inverter runs at different frequencies, different speed loop PI parameters can be selected. When the running frequency is less than the switching frequency 1 (P2-02), the speed loop PI adjustment parameters are P2-00 and P2-01. When the running frequency is greater than the switching frequency 2, the speed-to-PI adjustment parameters are P2-03 and P3-04. The speed loop PI parameters between switching frequency 1 and switching frequency 2 are linearly switched between two sets of PI parameters, as shown in Figure 7-2:

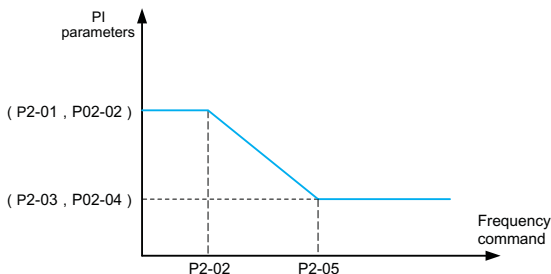

Fig.6-2 Schematic diagram of PI parameters

By setting the proportional coefficient and integral time of the speed regulator, the speed dynamic response characteristics of the vector control can be adjusted.

Increasing the proportional gain and reducing the integral time can speed up the dynamic of the speed loop. However, if the proportional gain is too large or the integral time is too small, the system may oscillate. The suggested adjustment method is:

If the factory parameters can not meet the requirements, fine-tune on the basis of the factory default parameters, first increase the proportional gain to ensure that the system does not oscillate; then reduce the integral time, so that the system has faster response characteristics and less overshoot.

Note: If the PI parameter is not set properly, it may cause the speed overshoot to be too large. Even an overvoltage fault occurs when the overshoot falls back.

Function code	Name	Description (setting range)	Factory Default	Change
P2-06	Vector control slip gain	50%~200%	100%	☆

For open-loop vector control, this parameter is used to adjust the speed stabilization accuracy of the motor: when the motor is loaded with a low speed, increase this parameter, and vice versa.

For closed-loop vector control, this parameter can adjust the output current of the inverter under the same load.

Function code	Name	Description (setting range)	Factory Default	Change
P2-07	SVC speed feedback filter time	0.000s~0.100s	0.015s	☆

In the vector control mode, the output of the speed loop regulator is the torque current command, and this parameter is used to filter the torque command.

This parameter generally does not need to be adjusted. When the speed fluctuation is large, the filter time can be appropriately increased; if the motor oscillates, this parameter should be appropriately reduced.

The filter time constant of the speed loop is small, and the output torque of the inverter may fluctuate greatly, but the speed response is fast.

Function code	Name	Description (setting range)	Factory Default	Change
P2-09	Torque upper limit command selection in speed control mode	0~7	0	☆

Function code	Name	Description (setting range)	Factory Default	Change
P2-10	Digital setting of torque upper limit in speed control mode	0.0%~200.0%	140%	☆

In the speed control mode, the maximum output torque of the inverter is controlled by the torque upper limit setting.

P2-09 is used to select the setting of the upper limit of torque. When it is set by analog quantity, PULSE pulse and communication, the corresponding 100% of the setting corresponds to P2-10, and the 100% of P2-10 is the rated torque of the inverter. E7 High Precision Closed-loop Vector Inverter Chapter 7 Function Details

For the settings of AI1, AI2, and AI3, see the introduction to the AI curve of group P4 (select the respective curve through P4-33)

For PULSE pulse, see the introduction of P4-28~P4-32

When the communication setting is selected, if the current slave is a point-to-point communication slave and the received data is used as the torque reference, the torque digital setting will be sent directly by the host, see the introduction of point-to-point communication in Group A8. Otherwise, the data of -100.00% to 100.00% is written by the host computer through the communication address 0x1000, of which 100.00% corresponds to P2-10. Support MODBUS, CANopen.

Function code	Name	Description (setting range)	Factory Default	Change
P2-13	Excitation adjustment proportional gain	0~60000	2000	☆
P2-14	Excitation adjustment integral gain	0~60000	1300	☆

The vector control current loop PI adjustment parameter, this parameter will be automatically obtained after the asynchronous machine is fully self-learning, and generally does not need to be modified.

It should be reminded that the integral regulator of the current loop does not use the integral time as the dimension, but directly sets the integral gain. If the current loop PI gain is set too large, it may cause the entire control loop to oscillate. Therefore, when the current oscillation or torque fluctuation is large, the PI proportional gain or integral gain here can be manually reduced.

Group P3: V/F Control Parameters of Motor

This group of function codes is only valid for V/F control and invalid for vector control.

V/F control is suitable for general-purpose loads such as fans and pumps, or one inverter with multiple motors, or applications where the power of the inverter and the motor are quite different.

Function code	Name	Description (setting range)	Factory Default	Change
P3-00	V/f curve setting	0~11	0	★

0: Linear V/F.

Suitable for ordinary constant torque loads.

1: Multi-point V/F.

Suitable for special loads such as dehydrators and centrifuges. At this time, by setting the parameters P3-03~P3-08, any V/F relationship curve can be obtained.

2: Square V/F.

Suitable for centrifugal loads such as fans and pumps.

3 to 8:

A V/F relationship between straight V/F and squared V/F.

10: V/F fully separated mode.

At this time, the output frequency and output voltage of the inverter are independent of each other, the output frequency is determined by the frequency setting, and the output voltage is determined by P3-13 (V/F separation voltage setting). V/F complete separation mode, generally used in induction heating, inverter power supply, torque motor control and other occasions.

11: V/F half separation mode.

In this case, V and F are proportional, but the proportional relationship can be set by voltage setting P3-13, and the relationship between V and F is also related to the rated voltage and rated frequency of the motor in group P1. Assuming that the voltage setting input is X (X is a value of 0~100%), the relationship between the output voltage V of the inverter and the frequency F is:

$$V/F=2 \times X \times (\text{motor rated voltage}) / (\text{motor rated frequency})$$

Function code	Name	Description (setting range)	Factory Default	Change
P3-01	Torque boost	0.0%: (without torque boost) 0.1%~30.0%	Model dependent	☆
P3-02	Torque boost cut-off frequency	0.00Hz~Maximum frequency	50.00Hz	★

In order to compensate the low frequency torque characteristic of V/F control, some boost compensation is made to the output voltage of the inverter at low frequency. However, if the torque boost setting is too large, the motor is easily overheated, and the inverter is prone to overcurrent.

When the load is heavy and the motor starting torque is not enough, it is recommended to increase this parameter. Torque boost can be reduced at light loads. When the torque boost is set to 0.0, the inverter is automatic torque boost. At this time, the inverter automatically calculates the required torque boost value according to the motor stator resistance and other parameters.

Torque boost torque cut-off frequency: Below this frequency, the torque boost torque is valid, and if it exceeds this set frequency, the torque boost becomes invalid. See Figure 6-3 for details.

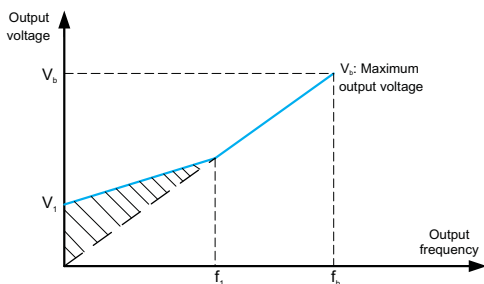

V_1 : Manual torque boost voltage

V_b : Maximum output voltage

f_i : Cutoff frequency of manual torque boost

f_b : Rated running frequency

Fig.6-3 Manual torque boost

Function code	Name	Description (setting range)	Factory Default	Change
P3-03	Multipoint V/F Frequency Point 1	0.00Hz~P3-05	0.00Hz	★
P3-04	Multipoint V/F Voltage Point 1	0.0%~100.0%	0.0%	★

Function code	Name	Description (setting range)	Factory Default	Change
P3-05	Multipoint V/F Frequency Point 2	P3-03~P3-07	0.00Hz	★
P3-06	Multipoint V/F Voltage Point 2	0.0%~100.0%	0.0%	★

These six parameters are used to define the multi-point V/F curve.

The multi-point V/F curve is set based on the motor's load characteristic. The relationship between voltages and frequencies is:

$$V1 < V2 < V3, P1 < P2 < P3$$

At low frequency, higher voltage may cause overheat or even burnt out of the motor and overcurrent stall or overcurrent protection of the AC drive.

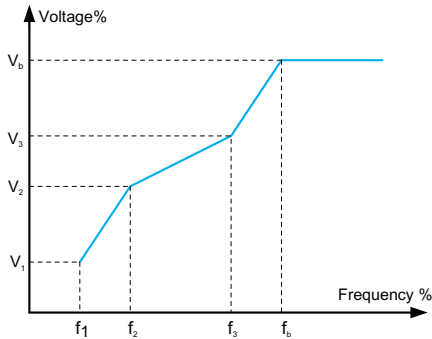

V_1 - V_3 : The percentage of the voltage of the 1st-3rd stage of the multi-speed V/F

f_1 - f_3 : Frequency percentage of 1st-3rd stage of multi-speed V/F

V_b : Rated motor voltage

f_b : Rated motor running frequency

Fig.6-4 V/F curve setting diagram

Function code	Name	Description (setting range)	Factory Default	Change
P3-11	V/F oscillation suppression factor	0~100	40	☆

The selection method of this gain is to take it as small as possible on the premise of effectively suppressing oscillation, so as to avoid adverse effects on the V/F operation. Please sele-

ct this gain as 0 when the motor has no oscillation phenomenon. Only when the motor oscillates significantly, it is necessary to increase the gain appropriately. The larger the gain, the more obvious the suppression of oscillation.

When using the oscillation suppression function, the rated current and no-load current parameters of the motor are required to be accurate, otherwise the V/F oscillation suppression effect will not be good.

Function code	Name	Description (setting range)	Factory Default	Change
P3-13	V/F separated voltage source	0~8	0	☆

V/F separation is generally used in induction heating, inverter power supply and torque motor control and other occasions.

When V/F separation control is selected, the output voltage can be set by function code P3-14, or it can be given by analog quantity, multi-segment command, PLC, PID or communication. When non-digital setting is used, 100% of each setting corresponds to the rated voltage of the motor. When the percentage of analog output setting is a negative number, the absolute value of the setting is used as the effective setting value.

0: Digital setting (P3-14)

The voltage is set directly by P3-14.

1: AI1

2: AI2

The voltage is determined by the analog input terminals.

4. PULSE pulse setting (DI5)

The voltage given is given by the terminal pulse. Pulse given signal specifications: voltage range 9V ~ 30V, frequency range 0kHz ~ 100kHz.

5. Multi-segment instructions

When the voltage is set as a multi-segment command, the parameters of the P4 group and the PC group should be set to determine the corresponding relationship between the given signal and the given voltage.

6. Program running

When the voltage is set to run the program, it is necessary to set the PC group parameters to determine the given output voltage.

7. PID

The output voltage is generated according to the PID closed loop. For details, see the introduction of PA group PID.

8. Communication given

Refers to the voltage given by the host computer through communication. When the above voltage setting is selected from 1 to 8, 0 to 100% corresponds to the output voltage from 0V to the rated voltage of the motor.

Function code	Name	Description (setting range)	Factory Default	Change
P3-14	Voltage digital setting for V/F separation	0V~motor rated voltage	0V	☆
P3-15	Voltage acceleration time for V/F separation	0.0s~1000.0s	0.0s	☆

The rise time of V/F separation refers to the time required for the output voltage to change from 0V to the rated voltage of the motor. As shown in Figure 6-5:

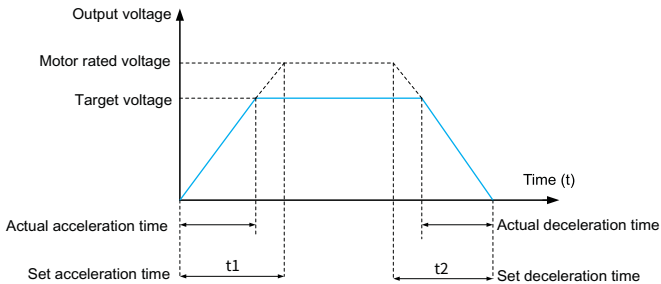

Fig.6-5 V/F Separation Schematic

Group P4: Analog and Pulse Input

The A800N inverter comes standard with 5 multi-function digital input terminals (where DI5 can be used as a high-speed pulse input terminal), 2 analog input terminals, and DI6~DI10 are the terminals on the expansion board.

Function code	Name	Description (setting range)	Factory Default	Change
P4-00	Function of terminal X1	0~49	0	★
P4-01	Function of terminal X2		4	★
P4-02	Function of terminal X3		9	★
P4-03	Function of terminal X4		12	★
P4-04	Function of terminal X5		13	★
P4-05	Function of terminal X6		0	★

These parameters are used to set the functions of the digital multi-function input terminals. The functions that can be selected are shown in the table below:

Value	Function	Description
0	No function	Unused terminals can be set to "No function" to prevent malfunction.
1	Forward RUN (FWD)	Control the forward and reverse rotation of the inverter through external terminals.
2	Reverse RUN (REV)	
3	3-wire operation control	Through this terminal, it is determined that the operating mode of the inverter is the three-wire control mode. For details, please refer to the description of function code P4-11 ("terminal command mode").
4	Forward jog	FJOG is jogging forward running, RJOG is jogging reverse running. For the jog running frequency and jog acceleration/deceleration time, please refer to the description of function codes P8-00, P8-01 and P8-02.
5	Reverse jog	
6	Terminal UP	When the frequency is given by the external terminal, it is used to modify the increment and decrement commands of the frequency. When the frequency setting is set to digital setting, the set frequency can be adjusted up and down.
7	Terminal DOWN	

Value	Function	Description
8	Free parking	The inverter blocks the output, and the motor's stopping process is not controlled by the inverter at this time. This method has the same meaning as the free parking described in P6-10.
9	Fault reset (RESET)	Use the terminal to perform fault reset function. Same function as the RESET key on the keyboard. With this function, remote fault reset can be realized.
10	Run pause	The inverter decelerates to stop, but all running parameters are memorized. Such as PLC parameters, swing frequency parameters, PID parameters. After the terminal signal disappears, the inverter returns to the running state before stopping.
11	External fault normally open input	When the signal is sent to the inverter, the inverter will report fault EF, and handle the fault according to the fault protection action mode (see function code P9-47 for details).
12	Multi-speed terminal 1	Through the 16 states of these four terminals, the setting of 16 speeds or 16 other commands can be realized.
13	Multi-speed terminal 2	
14	Multi-speed terminal 3	
15	Multi-speed terminal 4	
16	Acc/ Dec time selection 1	Through the 4 states of the two terminals, 4 kinds of acceleration and deceleration time selections can be realized. For details, see Appendix 2.
17	Acc/ Dec time selection 2	
18	Frequency source switchover	Used to switch between different frequency settings. According to the setting of the frequency setting selection function code (P0-07), when switching between two frequency settings is set as the frequency setting, this terminal is used to switch between the two frequency settings.
19	UP/DOWN setting clear (terminal, keyboard)	When the frequency given is digital frequency given, this terminal can clear the frequency value changed by terminal UP/DOWN or keyboard UP/DOWN, so that the given frequency can be restored to the value set by P0-08.

Function code	Name	Description (setting range)	Factory Default	Change
P4-10	DI filter time	0.000s~1.000s	0.010s	☆

Set the software filter time of DI terminal status. If the input terminal is susceptible to interference and causes malfunction, this parameter can be increased to enhance the anti-interference ability. However, increasing the filter time will cause the response of the DI terminal to become slower.

Function code	Name	Description (setting range)	Factory Default	Change
P4-11	Terminal command method	0~3	0	★

This parameter defines four different ways to control the operation of the inverter through external terminals.

0: Two-wire mode 1

This mode is the most commonly used two-wire mode. The forward and reverse running of the motor are determined by the terminals D1x and D1y. The terminal function settings are as follows:

K1	K2	RUN command
0	0	STOP
1	0	Forward RUN
0	1	Reverse RUN
1	1	STOP

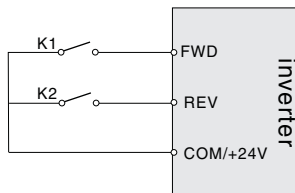

Fig.6-6 Two-wire operation mode 1

1: Two-wire operation mode 2

In this mode, FWD is the enable terminal. The direction is determined by the state of REV.

K1	K2	RUN command
0	0	STOP
0	1	STOP
1	0	Forward RUN
1	1	Reverse RUN

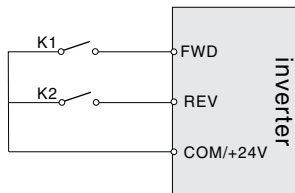

Fig.6-7 Two-wire operation mode 2

2: Three-wire operation mode 1

Din is the enable terminal in this mode, and the directions are controlled by FWD and REV respectively. But the pulse is valid, it must be done by disconnecting the Din terminal signal when stopping.

SB1: Stop button

SB2: Forward button

SB3: Invert button

Din is the multi-function input terminal of DI1~HDI, at this time, its corresponding terminal function should be defined as the No. 3 function "three-wire operation control".

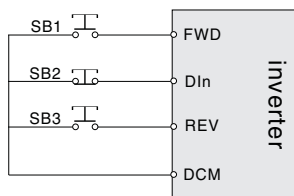

Fig.6-8 Three-wire operation mode 1

2: Three-wire operation mode

The enable terminal of this mode is Din, the running command is given by FWD, and the direction is determined by the state of REV.

The stop command is done by disconnecting the Din signal.

SB1: Stop button

SB2: Run button

Din is the multi-function input terminal of DI1~HDI, and its corresponding terminal function should be defined as the No. 3 function "three-wire operation control".

K	RUN command
0	Forward RUN
1	Reverse RUN

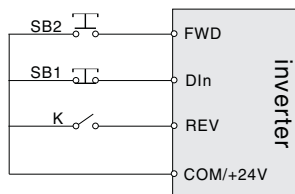

Fig.6-9 Three-wire operation mode 2

Par.	Designation	Scope	Default	Attr
P4-12	Terminal UP/DOWN change rate	0.001Hz/s~65.535Hz/s	0.0s	☆

It is used to set the speed of frequency change when the terminal UP/DOWN adjusts the set frequency, that is, the change amount of the frequency per second. When P0-22 (frequency decimal point) is 2, the value range is 0.001Hz/s~ 65.535Hz/s. When P0-22 (frequency decimal point) is 1, the value range is 0.01Hz/s~ 655.35Hz/s.

Par.	Designation	Scope	Default	Attr
P4-13	AI curve 1 minimum input	0.00V~P4-15	0.00V	☆
P4-14	AI curve 1 minimum input corresponding setting	-100.0%~+100.0%	0.00%	☆
P4-15	AI curve 1 maximum input	P4-13~+10.00V	10.00V	☆
P4-16	AI curve 1 maximum input corresponding setting	-100.0%~+100.0%	100.00%	☆
P4-17	AI1 filter time	0.00s~10.00s	0.10s	☆

The above function codes are used to set the relationship between the analog input voltage and the set value it represents.

When the voltage of the analog input is greater than the set "maximum input" (P4-15), the analog voltage is calculated according to the "maximum input"; similarly, when the analog input voltage is less than the set "minimum input" (P4-13), according to the setting of "AI lower than the minimum input setting selection" (P4-34), it is calculated by the minimum input or 0.0%.

When the analog input is current input, 1mA current is equivalent to 0.5V voltage.

AI1 input filter time is used to set the software filter time of AI1. When the on-site analog quantity is easily disturbed, please increase the filter time to stabilize the detected analog quantity. The response speed is slow, and how to set it needs to be weighed according to the actual application.

In different applications, the meaning of the nominal value corresponding to 100.0% of the analog setting is different. For details, please refer to the description of each application section.

The following illustrations show two typical settings:

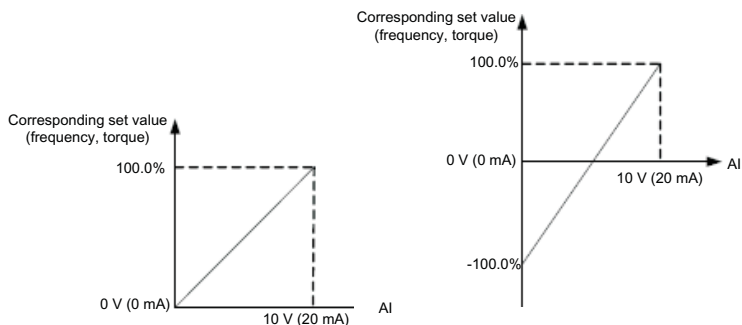

Fig.6-10 Corresponding relationship between analog given and set quantity

Par.	Designation	Scope	Default	Attr
P4-18	AI curve 2 minimum input	0.00V~P4-20	0.00V	☆
P4-19	AI curve 2 minimum input corresponding setting	-100.0%~+100.0%	0.00%	☆
P4-20	AI curve 2 max input	P4-18~+10.00V	10.00V	☆
P4-21	AI curve 2 maximum input corresponding setting	-100.0%~+100.0%	100.0%	☆
P4-22	AI2 filter time	0.00s~10.00s	0.10s	☆

For the function and usage of curve 2, please refer to the description of curve 1.

Par.	Designation	Scope	Default	Attr
P4-23	AI Curve 3 Minimum Input	-10.00V~P4-25	-10.00V	☆
P4-24	AI curve 3 minimum input corresponding setting	-100.0%~+100.0%	-100.00%	☆
P4-25	AI curve 3 max input	P4-23~+10.00V	10.00V	☆
P4-26	AI curve 3 maximum input corresponding setting	-100.0%~+100.0%	100.0%	☆

For the function and usage of curve 3, please refer to the description of curve 1.

Par.	Designation	Scope	Default	Attr
P4-28	Pulse input minimum frequency	0.00kHz~P4-30	0.00kHz	☆
P4-29	Pulse minimum input frequency corresponding setting	-100.0%~+100.0%	0.00%	☆
P4-30	Pulse maximum input frequency	P4-28~100.00kHz	50.00kHz	☆
P4-31	Pulse maximum input frequency corresponding setting	-100.0%~+100.0%	100.0%	☆
P4-32	Pulse filter time	0.00s~10.00s	0.10s	☆

This group of function codes is used to set the relationship between the DI5 pulse frequency and the corresponding setting.

The pulse frequency can only be input to the inverter through DI5 channel.

Par.	Designation	Scope	Default	Attr
P4-33	AI curve selection	Ones place: 1~3 Tens place:1~3	321	☆

The units and tens of the function code are used to select the corresponding setting curve of analog input AI1 and AI2.

The 2 analog inputs can select any one of the 3 curves respectively.

Curve 1, Curve 2, and Curve 3 are all 2-point curves, which are set in the P4 group function code.

The inverter standard unit provides 2 analog input ports.

Par.	Designation	Scope	Default	Attr
P4-34	AI is lower than the minimum input setting selection	Ones place: 0~1 Tens place:0~1	0	☆

This function code is used to set, when the voltage of the analog input is less than the set "minimum input", how to determine the setting corresponding to the analog.

The ones and tens of the function code correspond to the analog inputs AI1 and AI2 respectively. If 0 is selected, when the AI input is lower than the "minimum input", the corresponding setting of the analog quantity is the curve "minimum input corresponding setting" (P4-14, P4-19) determined by the function code.

If 1 is selected, when the AI input is lower than the minimum input, the corresponding setting of the analog quantity is 0.0%.

Par.	Designation	Scope	Default	Attr
P4-35	X1 delay time	0.0s~3600.0s	0.0s	★
P4-36	X2 delay time	0.0s~3600.0s	0.0s	★
P4-37	X3 delay time	0.0s~3600.0s	0.0s	★

It is used to set the delay time of the inverter for the change when the state of DI terminal changes.

Currently, only DI1, DI2, and DI3 have the function of setting the delay time.

Par.	Designation	Scope	Default	Attr
P4-34	Digital input terminal X valid mode selection 1	0~1	★	☆

It is used to set the valid state mode of the digital input terminal. When it is selected to be active at high level, it is valid when the corresponding DI terminal is connected to COM, and invalid when disconnected. When it is selected to be active at low level, the corresponding DI terminal is invalid when connected with COM, and valid when disconnected.

Group P5: Analog and Pulse Output

The inverter comes standard with 1 multi-function analog output terminal, 1 multi-function digital output terminal, 1 multi-function relay output terminal, and 1 FM terminal (can be selected as high-speed pulse output terminal or as open collector switch output).

Par.	Designation	Scope	Default	Attr
P5-00	Y/DO output function selection	0~1	0	☆

The FM terminal is a programmable multiplexing terminal, which can be used as a high-speed pulse output terminal (FMP) or an open-collector switching output terminal (FMR).

When outputting FMP as a pulse, the maximum frequency of the output pulse is 100kHz. Please refer to the description of P5-06 for the related functions of FMP.

Par.	Designation	Scope	Default	Attr
P5-01	Y terminal function selection (open collector output terminal)	0~38	0	☆
P5-02	Control board relay function selection (TA-TB-TC)		2	☆

The above 4 function codes are used to select the functions of 3 digital outputs.

The function description of the multi-function output terminal is as follows:

Value	Function	Description
0	No output	The output terminal has no function.
1	The inverter is running	Indicates that the inverter is running and has an output frequency (which can be zero), and the ON signal is output at this time.
2	Fault output (stop)	When the inverter fails, output ON signal.
3	Frequency level detection 1	Please refer to the description of function codes P8-19 and P8-20.
4	Frequency arrives	Please refer to the description of function code P8-21.
5	Running at zero speed	When the inverter is running and the output frequency is 0, the ON signal is output. When the inverter is in stop state, this signal is OFF.

Value	Function	Description
6	Motor overload pre-alarm	Before the overload protection of the motor acts, it is judged according to the overload pre-alarm threshold, and the ON signal is output after the pre-alarm threshold is exceeded. Refer to function codes P9-00~P9-02 for the motor overload parameter setting.
7	Inverter overload pre-alarm	10s before the inverter overload protection occurs, the ON signal is output.
8	Set the count value to reach	When the count value reaches the value set by PB-08, the ON signal is output.
9	The specified count value is reached	When the count value reaches the value set by PB-09, the ON signal is output. For the counting function, please refer to the description of the PB group function.
10	Length arrives	When the detected actual length exceeds the length set by PB-05, the ON signal will be output.
11	PLC cycle completed	When the program runs a cycle, a pulse signal with a width of 250ms is output.
12	Accumulated running time reached	When the accumulated running time of the inverter exceeds the time set by P8-17, it will output ON signal.
13	Frequency limited	When the set frequency exceeds the upper limit frequency or the lower limit frequency, and the output frequency of the inverter also reaches the upper limit frequency or the lower limit frequency, the ON signal is output.
14	Torque limit	When the inverter is in the speed control mode, when the output torque reaches the torque limit value, the inverter is in the stall protection state and outputs the ON signal at the same time.
15	Ready to run	When the power supply of the main circuit and control circuit of the inverter has been stabilized, and the inverter has not detected any fault information, and the inverter is in a running state, the ON signal is output.
16	AI1>AI2	When the value of the analog input AI1 is greater than the input value of AI2, the ON signal is output.
17	Upper limit frequency reached	When the running frequency reaches the upper limit frequency, the ON signal is output.
18	The lower limit frequency is reached (no output when stopped)	When the running frequency reaches the lower limit frequency, the ON signal is output. In stop state, this signal is OPF.

Value	Function	Description
19	Brown-out status output	When the inverter is under voltage state, it outputs ON signal.
20	Communication settings	Please refer to the communication protocol.
21	Reserve	Reserve
22	Reserve	Reserve
23	Running at zero speed 2 (also output when stopped)	When the output frequency of the inverter is 0, the ON signal is output. This signal is also ON in stop state.
24	The cumulative power-on time arrives	When the accumulative power-on time of the inverter (P7-13) exceeds the time set by P8-16, the output ON signal.
25	Frequency level detection FDT2 output	Please refer to the description of function codes P8-28 and P8-29.
26	Frequency 1 arrives at the output	Please refer to the description of function codes P8-30 and P8-31.
27	Frequency 2 arrives at the output	Please refer to the description of function codes P8-32 and P8-33.
28	Current 1 reaches the output	Please refer to the description of function codes P8-38 and P8-39.
29	Current 2 reaches the output	Please refer to the description of function codes P8-40 and P8-41.
30	Timed arrival output	When the timing function selection (P8-42) is valid, the inverter will output ON signal after the current running time reaches the set timing time.
31	AI1 input overrun	When the value of analog input AI1 is greater than P8-46 (AI1 input protection upper limit) or smaller than P8-45 (AI1 input protection lower limit), the ON signal is output.
32	Downloading	When the inverter is in the state of off-load, the ON signal is output.
33	Running in reverse	When the inverter is running in reverse, output ON signal
34	Zero current state	Please refer to the description of function codes P8-28 and P8-29
35	Module temperature reached	When the inverter module radiator temperature (P7-07) reaches the set module temperature reaching value (P8-47), the ON signal is output

Value	Function	Description
36	Software current overrun	Please refer to the description of function codes P8-36 and P8-37.
37	The lower limit frequency is reached (the output is also output when the machine is stopped)	When the running frequency reaches the lower limit frequency, the ON signal is output. This signal is also ON in the stop state.
38	Alarm output (continue running)	When a fault occurs in the inverter, and the processing mode of the fault is to continue running, the inverter will output an alarm.

Par.	Designation	Scope	Default	Attr
P5-06	DO output function selection	0~16	0	☆
P5-07	AO output function selection		0	☆
P5-08	Reserve		1	☆

FMP terminal output pulse frequency range is 0.01kHz~P5-09 (FMP output maximum frequency), P5-09 can be set between 0.01kHz~100.00kHz.

The output range of analog output AO1 is 0V~10V, or 0mA~20mA. The scaling relationship between the range of pulse output or analog output and the corresponding function is shown in the following table:

Value	Function	Description
0	Running frequency	0 ~ Maximum output frequency
1	Set frequency	0 ~ Maximum output frequency
2	Output current	0 to 2 times the rated current of the motor
3	Motor output torque (absolute value, percentage relative to the motor)	0 to 2 times the rated torque of the motor
4	Output power	0 ~ 2 times rated power
5	Output voltage	0 ~ 1.2 times the rated voltage of the inverter
6	Pulse input (100.0% corresponds to 100.0kHz)	0.01kHz ~ 100.00kHz
7	AI1	0V ~ 10V

Value	Function	Description
8	AI2	0V ~ 10V (or 0 ~ 20mA)
9	Reserved	Reserved
10	length	0 ~ Maximum set length
11	count value	0 ~ Maximum count value
12	Communication settings	0.0% ~ 100.0%
13	Motor speed	0 to the speed corresponding to the maximum output frequency
14	Output current (100.0% corresponds to 1000.0A)	0.0A ~ 1000.0A
15	Output voltage (100.0% corresponds to 1000.0V)	0.0V ~ 1000.0V
16	Motor output torque (actual value, percentage relative to motor)	-2 times the rated torque of the motor ~ 2 times the rated torque of the motor

Par.	Designation	Scope	Default	Attr
P5-09	DO output maximum frequency	0.01kHz~100.00kHz	50.00kHz	☆

When the FM terminal is selected as the pulse output, this function code is used to select the maximum frequency value of the output pulse.

Par.	Designation	Scope	Default	Attr
P5-10	AO zero bias coefficient	0	0.00%	☆
P5-11	AO gain	-10.00~+10.00	1	☆

The above function codes are generally used to correct the zero drift of the analog output and the deviation of the output amplitude. It can also be used to customize the desired AO output curve.

If the zero offset is represented by "b", the gain is represented by k, the actual output is represented by Y, and the standard output is represented by X, the actual output is:

$Y=kX+b$. Among them, the zero offset coefficient of AO1 is 100% corresponding to 10V (or 20mA), and the standard output refers to the output of 0V ~ 10V (or 0mA ~ 20mA) corresponding to the analog output without zero offset and gain correction.

For example: if the analog output content is the running frequency, and you want to output 8V when the frequency is 0, and output 3V when the frequency is the maximum frequency, the gain should be set to "-0.50", and the zero offset should be set to "80%".

Par.	Designation	Scope	Default	Attr
P5-17	DO output delay time	0.0s~3600.0s	0.0s	☆
P5-18	Relay output delay time	0.0s~3600.0s	0.0s	☆
P5-20	DO output delay time	0.0s~3600.0s	0.0s	☆
P5-22	DO output terminal valid state selection	-100.0%~+100.0%	0	☆

Set the delay time from the status change of the output terminal FMR, relay and DO to the actual output change.

Group P6: Start/Stop Control

Par.	Designation	Scope	Default	Attr
P6-00	Start method	0~2	0	★

0: direct start

If the starting DC braking time is set to 0, the inverter starts to run from the starting frequency. If the starting DC braking time is not 0, the DC braking will be performed first, and then the operation will start from the starting frequency. It is suitable for small inertia loads, and the motor may rotate when starting.

1: Speed tracking restart

The inverter first judges the speed and direction of the motor, and then starts at the tracked motor frequency, and implements a smooth and shock-free start to the rotating motor. It is suitable for instantaneous power failure and restart of large inertia loads. In order to ensure the performance of the speed tracking restart, it is necessary to set the parameters of the motor P1 group accurately.

2: Asynchronous motor pre-excitation start

Only valid for asynchronous motors, it is used to build up the magnetic field before the motor runs. For pre-excitation current and pre-excitation time, please refer to the description of function codes P6-05 and P6-06.

If the pre-excitation time is set to 0, the inverter cancels the pre-excitation process and starts from the starting frequency. If the pre-excitation time is not 0, the pre-excitation is performed before starting, which can improve the dynamic response performance of the motor.

Par.	Designation	Scope	Default	Attr
P6-01	Speed tracking method	0~2	0	★

In order to complete the speed tracking process in the shortest time, select the method for the inverter to track the motor speed:

- 0: Track down from the frequency at the time of power failure, this method is usually selected.
- 1: Start tracking upwards from 0 frequency, and use it in the case of restarting after a long power outage.
- 2: Track down from the maximum frequency, generally used for power generation loads.

Par.	Designation	Scope	Default	Attr
P6-02	Speed tracking speed	1~100	20	☆

When the speed tracking is restarted, select the speed of the speed tracking.

The larger the parameter, the faster the tracking speed. But setting too large may cause unreliable tracking effect.

Par.	Designation	Scope	Default	Attr
P6-03	Start frequency	0.00Hz~10.00Hz	0.00Hz	☆
P6-04	Start frequency hold time	0.0s~100.0s	0.0s	★

To ensure the motor torque when starting, please set an appropriate starting frequency. In order to fully build up the magnetic flux when the motor starts, the starting frequency needs to be maintained for a certain period of time.

The starting frequency P6-03 is not limited by the lower frequency limit. But when the set target frequency is less than the start frequency, the inverter will not start and is in the standby state.

During the forward/reverse switching process, the start frequency holding time does not work. The starting frequency holding time is not included in the acceleration time, but is included in the running time of the program running.

Example 1:

P0-03=0 frequency is set as digital given

P0-08=2.00Hz digital setting frequency is 2.00Hz

P6-03=5.00Hz starting frequency is 5.00Hz

P6-04=2.0s start frequency holding time is 2.0s

At this time, the inverter will be in the standby state, and the output frequency of the inverter is 0.00Hz.

Example 2:

P0-03=0 frequency is set as digital given

P0-08=10.00Hz digital setting frequency is 10.00Hz

P6-03=5.00Hz starting frequency is 5.00Hz

P6-04=2.0s start frequency holding time is 2.0s

At this time, the inverter accelerates to 5.00Hz, after 2.0s, then accelerates to the given frequency 10.00Hz.

Par.	Designation	Scope	Default	Attr
P6-05	Start DC braking current /pre-excitation current	0%~100%	50%	★
P6-06	Start DC braking time/pre-excitation time	0.0s~100.0s	0.0s	★

Start DC braking, generally used to stop the running motor and then start it. Pre-excitation is used to make the asynchronous motor establish a magnetic field before starting, and improve the response speed.

Start DC braking is only valid when the start mode is direct start. At this time, the inverter first performs DC braking according to the set starting DC braking current, and then starts to run after the starting DC braking time. If the DC braking time is set to 0, it will start directly without DC braking. The greater the DC braking current, the greater the braking force.

If the starting mode is asynchronous machine pre-excitation start, the inverter will first establish a magnetic field according to the set pre-excitation current, and then start running after the set pre-excitation time. If the pre-excitation time is set to 0, it will start directly without going through the pre-excitation process.

The starting DC braking current/pre-excitation current is a percentage relative to the rated current of the inverter.

Par.	Designation	Scope	Default	Attr
P6-07	Acceleration and deceleration method	0~2	0	★

Select the frequency change mode during the start and stop of the inverter.

0: Linear acceleration and deceleration

The output frequency increases or decreases linearly.

1: S curve acceleration and deceleration A

The output frequency increases or decreases according to the S-curve. The S-curve is used where a gentle start or stop is required. Function codes P6-08 and P6-09 respectively define the time ratio of the start segment and end segment of S-curve acceleration and deceleration.

2: S curve acceleration and deceleration B

In this S-curve acceleration/deceleration B, the motor rated frequency PB is always the inflection point of the S-curve. As shown in Figure 7-12. It is generally used in the occasions where rapid acceleration and deceleration are required in the high-speed area above the rated frequency. When the set frequency is above the rated frequency, the acceleration/deceleration time is:

$$t = \left(\frac{4}{9} \times \left(\frac{f}{f_b} \right)^2 + \frac{5}{9} \right) \times T$$

Among them, f is the set frequency, PB is the rated frequency of the motor, and T is the time to accelerate from 0 frequency to rated frequency PB .

Par.	Designation	Scope	Default	Attr
P6-08	The proportion of time at the beginning of the S-curve	0.0%~(100.0%-P6-09)	30.00%	★
P6-09	The proportion of time at the end of the S-curve	0.0%~(100.0%-P6-08)	30.00%	★

Function codes P6-08 and P6-09 respectively define the time ratio of the start segment and end segment of S-curve acceleration and deceleration A. The two function codes must satisfy: $P6-08+P6-09 \leq 100.0\%$.

In Figure 6-11, t_1 is the parameter defined by parameter P6-08. During this period, the slope of output frequency changes gradually increases. t_2 is the time defined by parameter P6-09, and the slope of the output frequency change gradually changes to 0 during this time period. During the time between t_1 and t_2 , the slope of the output frequency change is fixed, that is, linear acceleration and deceleration are performed in this interval.

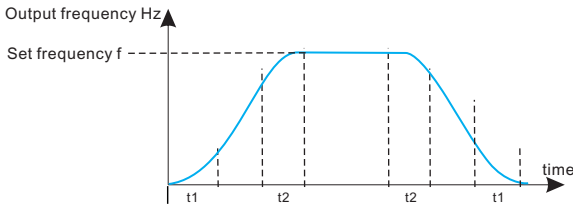

Figure 6-11. S-curve acceleration and deceleration A schematic diagram

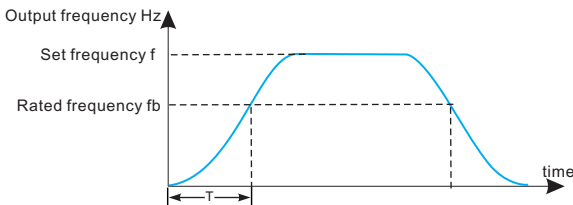

Figure 6-11. S-curve acceleration and deceleration B schematic diagram

Par.	Designation	Scope	Default	Attr
P6-10	Stop mode	0~1	0	☆

0: Decelerate to stop

After the stop command is valid, the inverter reduces the output frequency according to the deceleration time, and stops after the frequency drops to 0.

1: Free parking

After the stop command is valid, the inverter immediately stops the output, and the motor coasts to a stop according to the mechanical inertia.

Par.	Designation	Scope	Default	Attr
P6-11	DC braking starting frequency at stop	0.00Hz~Maximum frequency	0.00Hz	☆
P6-12	DC braking waiting time at stop	0.0s~100.0s	0.0s	☆
P6-13	Stop DC braking current	0.0%~100.0%	50%	☆
P6-14	DC braking time at stop	0.0s~100.0s	0.0s	☆

Start frequency of DC braking at stop: During the deceleration stop process, when the running frequency is reduced to this frequency, the DC braking process starts.

DC braking waiting time at stop: After the running frequency is reduced to the starting frequency of DC braking at stop, the inverter stops outputting for a period of time, and then starts the DC braking process. It is used to prevent faults such as overcurrent that may be caused by starting DC braking at higher speeds.

Stop DC braking current: refers to the output current during DC braking, the percentage relative to the rated current of the motor. The larger this value is, the stronger the DC braking effect is, but the greater the heating of the motor and the inverter.

Stop DC braking time: the time that the DC braking amount is maintained. If this value is 0, the DC braking process is cancelled. The DC braking process at stop is shown in the schematic diagram in Figure 7-13.

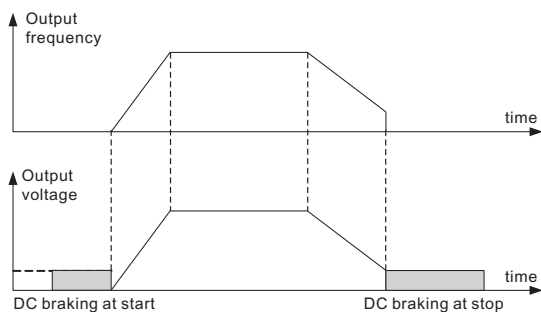

Figure 6-13. Schematic diagram of stop DC braking

Par.	Designation	Scope	Default	Attr
P6-15	Brake usage ratio	0.0%~100.0%	100%	☆

Only valid for inverters with built-in braking unit.

It is used to adjust the duty ratio of the moving unit. If the braking usage rate is high, the action duty ratio of the braking unit will be high and the braking effect will be strong, but the bus voltage of the inverter will fluctuate greatly during the braking process.

Group P7: Keys of Control panel

Par.	Designation	Scope	Default	Attr
P7-03	Run display parameter 1	0000~FFFF	1F	☆

When the inverter is running, the parameter display is affected by this function code, that is, it is a 16-bit binary number. If a digit is 1, the parameter corresponding to this digit can be viewed through the "SHIFT" key during running. . If this bit is 0, the parameter corresponding to this bit will not be displayed. When setting the function code P7-03, to convert the binary number to hexadecimal number, input this function code.

BIT15	BIT14	BIT13	BIT12	The fourth	
BIT11	BIT10	BIT9	BIT8	The third	
BIT7	BIT6	BIT5	BIT4	The second	
BIT3	BIT2	BIT1	BIT0	The first one	
0	0	0	0	0000	0
0	0	0	1	0001	1
0	0	1	0	0010	2
0	0	1	1	0011	3
0	1	0	0	0100	4
0	1	0	1	0101	5
0	1	1	0	0110	6
1	1	1	1	0111	7
1	0	0	0	1000	8
1	0	0	1	1001	9
1	0	1	0	1010	A
1	0	1	1	1011	B
1	1	0	0	1100	C
1	1	0	1	1101	D
1	1	1	0	1110	E
1	1	1	1	1111	F

The display content represented by the lower 8 bits is as follows:

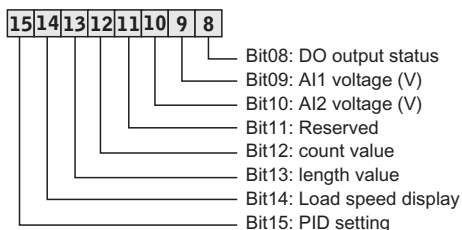
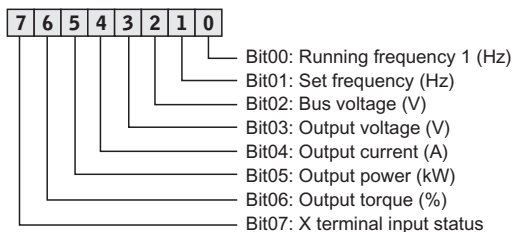

The status of the input and output terminals is displayed in decimal, X1 (Y1) corresponds to the lowest digit, for example, if the input status displays 3, it means that the terminals X1 and X2 are closed, and the other terminals are open.

Par.	Designation	Scope	Default	Attr
P7-04	Run display parameter 2	0000~FFFF	0	☆
P7-05	Stop display parameters	0000~FFFF	03	☆

The setting of this function is the same as that of P7-03.

Par.	Designation	Scope	Default	Attr
P7-06	Load speed display factor	0.0001~6.5000	-	★

When the load speed needs to be displayed, this parameter can be used to adjust the corresponding relationship between the output frequency of the inverter and the load speed. Refer to the description of P7-12 for the specific corresponding relationship.

Par.	Designation	Scope	Default	Attr
P7-07	Inverter module heat sink temperature	-20°C~120°C	-	●

Displays the temperature of the inverter module IGBT.

The IGBT over-temperature protection value of the inverter module of different models is different.

Par.	Designation	Scope	Default	Attr
P7-09	Cumulative running time	0h~65535h	-	●

Displays the accumulated running time of the inverter.

When the running time reaches the set running time P8-17, the multi-function digital output function (12) of the inverter outputs the ON signal.

Par.	Designation	Scope	Default	Attr
P7-11	Feature version number	software version number	21	●
P7-12	Load speed display decimal places	Ones place: 0~3 Tens place: 1~2	0.0s	☆

Used to set the number of decimal places for display of load speed. The following example shows how the load speed is calculated:

If the load speed display coefficient P7-06 is 2.000, the decimal point of the load speed P7-12 is 2 (2 decimal points), when the inverter running frequency is 40.00Hz, the load speed is: $40.00 \times 2.000 = 80.00$ (2 decimal points) show)

If the inverter is in the stop state, the load speed will be displayed as the speed corresponding to the set frequency, that is, "set load speed". Taking the set frequency of 50.00Hz as an example, the load speed in the shutdown state is: $50.00 \times 2.000 = 100.00$ (displayed with 2 decimal points)

Par.	Designation	Scope	Default	Attr
P7-14	Cumulative power consumption	0~65535 degrees	-	●

Displays the cumulative power-on time of the inverter from the factory.

When this time reaches the set power-on time (P8-17), the multi-function digital output function (24) of the inverter will output the ON signal.

Par.	Designation	Scope	Default	Attr
P7-14	Cumulative power consumption	0~65535 degrees	-	●

Displays the accumulated power consumption of the inverter so far.

Group P8: Auxiliary setting of operating frequency

Par.	Designation	Scope	Default	Attr
P8-00	Jog FREQ	0.00Hz~upper limit FREQ	2.00Hz	☆
P8-01	Jog Accel time	0.0s~6500.0s	20.0s	☆
P8-02	Jog Decel time	0.0s~6500.0s	20.0s	☆

Define the given frequency and acceleration/deceleration time of the inverter when jogging.

During jog operation, the startup mode is fixed as direct start (P6-00=0), and the stop method is fixed as deceleration stop (P6-10=0).

Par.	Designation	Scope	Default	Attr
P8-03	Accel time 2	0.0s~6500.0s	Model dependent	☆
P8-04	Decel time 2	0.0s~6500.0s	Model dependent	☆
P8-05	Accel time 3	0.0s~6500.0s	Model dependent	☆
P8-06	Decel time 3	0.0s~6500.0s	Model dependent	☆
P8-07	Accel time 4	0.0s~6500.0s	Model dependent	☆
P8-08	Decel time 4	0.0s~6500.0s	Model dependent	☆

The inverter provides 4 sets of acceleration and deceleration time, which are P0-17/P0-18 and the above 3 sets of acceleration and deceleration time.

The definitions of the 4 groups of acceleration and deceleration time are exactly the same, please refer to the relevant descriptions of P0-17 and P0-18. Through different combinations of multi-function digital input terminals DI, 4 groups of acceleration and deceleration time can be switched and selected. Please refer to the relevant instructions in function codes P4-01 to P4-05 for the specific usage.

Par.	Designation	Scope	Default	Attr
P8-09	Hop Frequency 1	0.00Hz~Maximum frequency	0.00Hz	☆
P8-10	Hop Frequency 2	0.00Hz~Maximum frequency	0.00Hz	☆
P8-11	Hop Frequency Amplitude	0.00Hz~upper limit FREQ	0.00Hz	☆

When the set frequency is within the jump frequency range, the actual operating frequency will run at the jump frequency closer to the set frequency. By setting the jump frequency, the inverter can avoid the mechanical resonance point of the load.

The inverter can set two jump frequency points. If both jump frequencies are set to 0, the jump frequency function will be cancelled. For the principle of hopping frequency and hopping frequency amplitude, please refer to Figure 6-14.

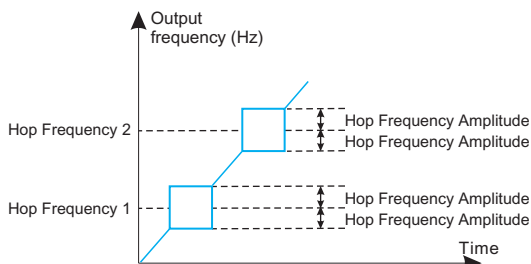

Fig.6-14 Schematic diagram of hopping frequency

Par.	Designation	Scope	Default	Attr
P8-12	Forward and reverse dead time	0.0s~3000.0s	0.00Hz	☆

Set the transition time at the output 0Hz during the forward/reverse transition of the inverter, as shown in Figure 6-15:

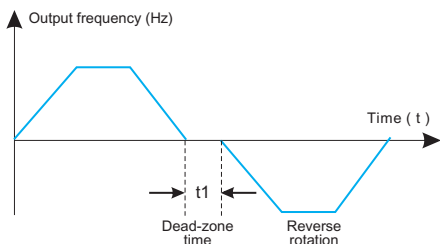

Fig.6-15 Schematic diagram of forward and reverse dead time

Par.	Designation	Scope	Default	Attr
P8-13	Reverse frequency prohibited	0~1	0	☆

This parameter is used to set whether the inverter is allowed to run in the reverse state. If the motor is not allowed to run in reverse, set P8-13=1.

Par.	Designation	Scope	Default	Attr
P8-14	The set frequency is lower than the lower limit frequency operation mode	0~2	0	☆

When the set frequency is lower than the lower limit frequency, the running state of the inverter can be selected by this parameter. The frequency converter offers three operating modes to meet various application needs.

Par.	Designation	Scope	Default	Attr
P8-15	Sag rate	0.00%~100.00%	0.00%	☆

The sag ratio allows for a slight speed difference between the master and slave stations, which in turn avoids collisions between them. The default value of this parameter is 0.

Only when the master and the slave use the speed control mode, the sag rate needs to be adjusted. For each transmission process, the appropriate sag rate needs to be gradually found in practice. It is recommended not to set P8-15 too large, otherwise the load When it is larger, the steady-state speed will decrease significantly. Both master and slave must set the droop rate.

Droop speed = synchronous frequency x output torque x droop rate + 10

For example: P8-15=1.00, synchronous frequency 50Hz, output torque 50%, then:

Drooping speed=50Hz×50%×1.00+10=2.5Hz

Inverter actual frequency=50Hz-2.5Hz=47.5Hz

Par.	Designation	Scope	Default	Attr
P8-16	Set the cumulative power-on arrival time	0h~65000h	0h	☆

When the accumulated power-on time (P7-13) reaches the power-on time set by P8-16, the multi-function digital DO of the inverter will output ON signal. The following examples illustrate its application:

Example: Combined with the virtual DI/DO function, after the set power-on time reaches 100 hours, the inverter fault alarm output. Program:

Virtual DI1 terminal function, set as user-defined fault 1: A1-00=44;

Virtual DI1 terminal valid state, set to come from virtual DO1: A1-05=0000;

Virtual DO1 function, set to arrive at power-on time: A1-11=24;

Set the accumulative power-on arrival time to 100 hours: P8-16=100.

Then when the accumulative power-on time reaches 100 hours, the inverter will output UdE1 for fault.

Par.	Designation	Scope	Default	Attr
P8-17	Set the cumulative operation arrival time	0h~65000h	0h	☆

Used to set the running time of the inverter.

When the accumulated running time (P7-09) reaches the set running time, the multi-function digital DO of the inverter will output ON signal.

Par.	Designation	Scope	Default	Attr
P8-18	Boot protection selection	0~1	0	☆

This parameter relates to the safety protection function of the inverter.

If this parameter is set to 1, if the running command is valid when the inverter is powered on (for example, the terminal running command is in the closed state before power-on), the inverter will not respond to the running command, and the running command must be canceled once, and the running command will be valid again after The inverter will respond.

In addition, if this parameter is set to 1, if the running command is valid at the time of inverter fault reset, the inverter will not respond to the running command, and the running command must be removed to eliminate the running protection state.

Setting this parameter to 1 can prevent the danger caused by the motor responding to the running command during power-on or fault reset without knowing it.

Par.	Designation	Scope	Default	Attr
P8-19	Frequency detection value 1	0.00Hz~upper limit FREQ	50.00Hz	☆
P8-20	Frequency detection hysteresis 1	0.0%~100.0% (PDT1 level)	5.00%	☆

When the running frequency is higher than the frequency detection value, the multi-function output DO of the inverter will output the ON signal, and when the frequency is lower than the detection value by a certain frequency value, the DO output ON signal will be cancelled.

The above parameters are used to set the detection value of the output frequency and the hysteresis value of the output action release. Among them, P8-20 is the percentage of the lag frequency relative to the frequency detection value P8-19. Figure 6-16 is a schematic diagram of the FDT function.

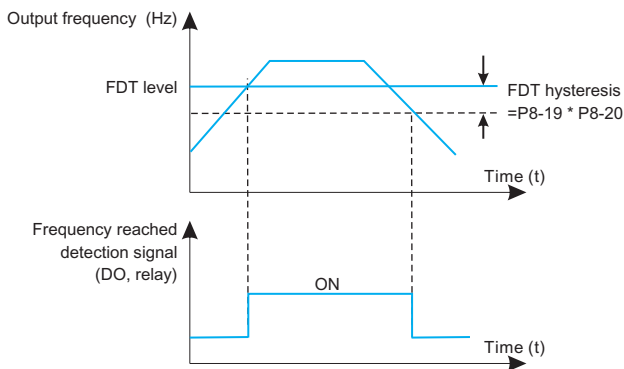

Fig.6-16 FDT level diagram

Par.	Designation	Scope	Default	Attr
P8-21	Frequency arrival detection amplitude	0.0%~100.0% (maximum frequency)	0.00%	☆

When the running frequency of the inverter is within a certain range of the target frequency, the multi-function DO of the inverter will output ON signal.

This parameter is used to set the detection range of frequency arrival, which is a percentage relative to the maximum frequency. Figure 6-17 is a schematic diagram of frequency arrival.

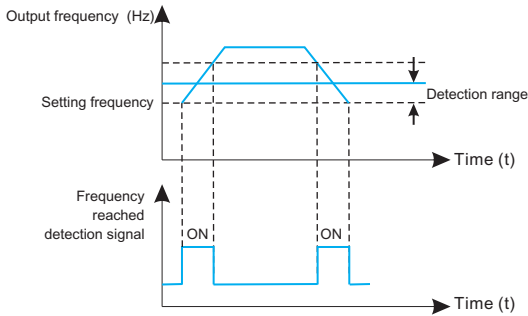

Fig.6-17 Schematic diagram of frequency arrival detection amplitude

Par.	Designation	Scope	Default	Attr
P8-22	Whether the jump frequency is valid during acceleration and deceleration	0: invalid	0	☆

This function code is used to set whether the skip frequency is valid during acceleration and deceleration.

When it is set to be valid, when the running frequency is in the jump frequency range, the actual running frequency will skip the set jump frequency boundary. Figure 6-18 is a schematic diagram of the effective jump frequency during acceleration and deceleration.

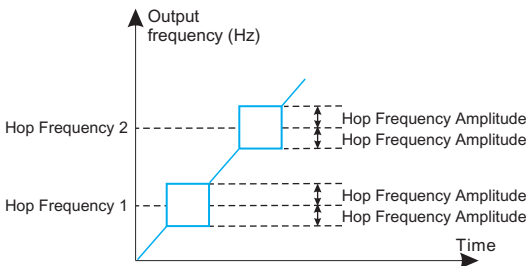

Fig.6-18 Schematic diagram of the effective jump frequency during acceleration and deceleration

Par.	Designation	Scope	Default	Attr
P8-25	Acceleration time 1 and acceleration time 2 switch frequency points	0.00Hz~Maximum frequency	0.00Hz	☆
P8-26	Deceleration time 1 and deceleration time 2 switch frequency points	0.00Hz~Maximum frequency	0.00Hz	☆

This function is valid when the motor is selected as motor 1 and the acceleration/deceleration time is not selected by switching the DI terminal. It is used to select different acceleration and deceleration time according to the running frequency range instead of DI terminal during the running process of the inverter.

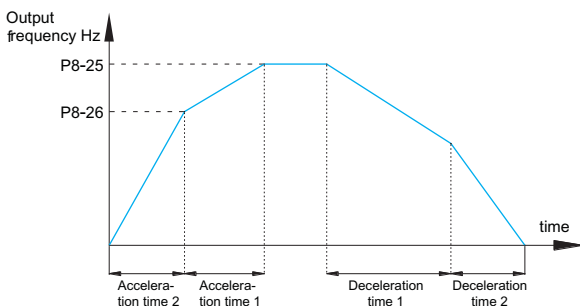

Fig.6-19 Schematic diagram of acceleration and deceleration time switching

Figure 7-19 is a schematic diagram of acceleration and deceleration time switching. During acceleration, if the running frequency is less than P8-25, select acceleration time 2; if the running frequency is greater than P8-25, select acceleration time 1.

During the deceleration process, if the running frequency is greater than P8-26, select deceleration time 1; if the running frequency is less than P8-26, select deceleration time 2.

Par.	Designation	Scope	Default	Attr
P8-27	Terminal jog priority	0~1	0	☆

This parameter is used to set whether the terminal jog function has the highest priority.

When the terminal jog priority is valid, if there is a terminal jog command during the running process, the inverter will switch to the terminal jog running state.

Par.	Designation	Scope	Default	Attr
P8-28	Frequency detection value 2	0.00Hz~Maximum frequency	50.00Hz	☆
P8-29	Frequency detection lag rate 2	0.0%~100.0% (PDT2 level)	5.00%	☆

This frequency detection function is exactly the same as that of FDT1, please refer to the relevant description of FDT1, that is, the description of function codes P8-19 and P8-20.

Par.	Designation	Scope	Default	Attr
P8-30	Arbitrary arrival frequency detection value 1	0.00Hz~Maximum frequency	50.00Hz	☆
P8-31	Arbitrary arrival frequency detection amplitude 1	0.0%~100.0% (maximum frequency)	0.00%	☆
P8-32	Arbitrary arrival frequency detection value 2	0.00Hz~Maximum frequency	50.00Hz	☆
P8-33	Arbitrary arrival frequency detection amplitude 2	0.0%~100.0% (maximum frequency)	0.00%	☆

When the output frequency of the inverter is within the range of the positive and negative detection amplitudes of any arrival frequency detection value, the multi-function DO outputs the ON signal.

The inverter provides two sets of parameters for detecting any arrival frequency, respectively setting the frequency value and the frequency detection range. Figure 7-20 is a schematic diagram of this function.

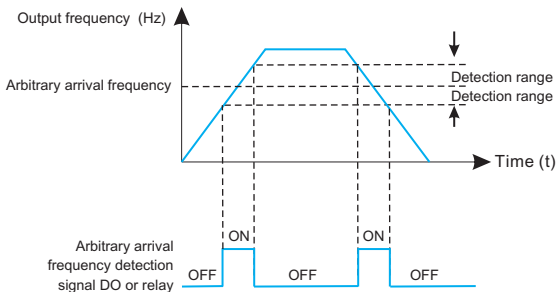

Fig.6-20 Schematic diagram of arbitrary arrival frequency detection

Par.	Designation	Scope	Default	Attr
P8-34	Zero current detection level	0.0%~300.0% 100.0% corresponds to the rated current of the motor	5.00%	☆
P8-35	Zero current detection delay time	0.01s~600.00s	0.10s	☆

When the output current of the inverter is less than or equal to the zero current detection level, and the duration exceeds the zero current detection delay time, the multi-function DO of the inverter outputs an ON signal. Figure 6-21 Schematic diagram of zero current detection.

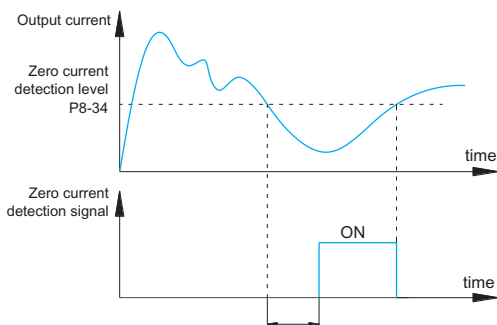

Fig.6-21 Schematic diagram of current detection

Par.	Designation	Scope	Default	Attr
P8-36	The output current exceeds the limit	0.0% (not detected) 0.1%~300.0% (motor rated current)	200.00%	☆
P8-37	Output current overrun detection delay time	0.01s~600.00s	0.00S	☆

When the output current of the inverter is greater than or exceeds the limit detection point, and the duration exceeds the software overcurrent point detection delay time, the multi-function DO of the inverter outputs the ON signal. Figure 7-22 is the schematic diagram of the output current over-limit function.

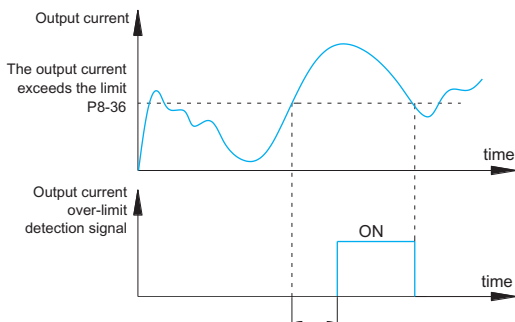

Fig.6-22 Schematic diagram of output current over-limit detection

Par.	Designation	Scope	Default	Attr
P8-38	Arbitrary arrival current 1	0.0%~300.0% (motor rated current)	100.00%	☆
P8-39	Arbitrary arrival current 1 amplitude	0.0%~300.0% (motor rated current)	0.00%	☆
P8-40	Arbitrary arrival current 2	0.0%~300.0% (motor rated current)	100.00%	☆
P8-41	Arbitrary arrival current 2 amplitude	0.0%~300.0% (motor rated current)	0.00%	☆

When the output current of the inverter is within the positive and negative detection width of any arrival current, the multi-function DO of the inverter will output the ON signal.

The inverter provides two sets of parameters of arbitrary arrival current and detection width. Figure 6-23 is a schematic diagram of the function.

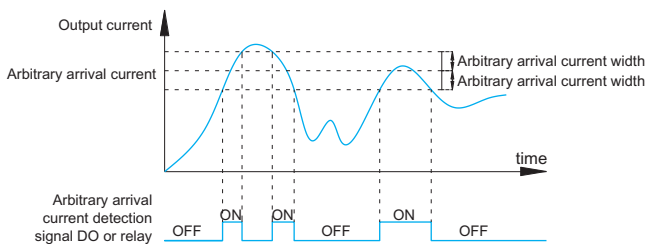

Fig.6-23 Arbitrary arrival current detection schematic diagram

Par.	Designation	Scope	Default	Attr
P8-42	Timing function selection	0~1	0	★
P8-43	Timing run time selection	0~2	0.00Hz	★
P8-44	Timing run time	0.0Min~6500.0Min	0.0Min	★

This group of parameters is used to complete the timing operation function of the inverter.

When the timing function selection of P8-42 is valid, the inverter starts timing when it starts, and when the set timing running time is reached, the inverter automatically stops, and the multi-function DO outputs ON signal at the same time.

Every time the inverter starts, it starts timing from 0, and the remaining running time of the timing can be checked through U0-20. The timing running time is set by P8-43 and P8-44, and the time unit is minutes.

Par.	Designation	Scope	Default	Attr
P8-45	Ai1 input voltage protection value lower limit	0.00V~P8-46	3.10V	☆
P8-46	Ai1 input voltage protection value upper limit	P8-45~10.00V	6.80V	☆

When the value of the analog input AI1 is greater than P8-46, or the AI1 input is less than P8-47, the multi-function DO of the inverter outputs the "AI1 input overrun" ON signal, which is used to indicate whether the input voltage of AI1 is within the setting range.

Par.	Designation	Scope	Default	Attr
P8-47	Module temperature reached	0°C~100°C	90°C	☆

When the temperature of the inverter radiator reaches this temperature, the multi-function DO of the inverter will output the ON signal of "module temperature reached".

Par.	Designation	Scope	Default	Attr
P8-48	Cooling Fan Control	0~1	0	☆

It is used to select the action mode of the cooling fan. When it is set to 0, the inverter will run the fan in the running state. If the radiator temperature is higher than 40 degrees in the stop state, the fan will run. In the stop state, the fan will not work when the radiator is lower than 40 degrees. run.

When 1 is selected, the fans run consistently after power-on.

Par.	Designation	Scope	Default	Attr
P8-49	wake up frequency	Sleep frequency (P8-51)~Maximum frequency (A0-10)	0.00Hz	☆
P8-50	Wake up delay time	0.0s~6500.0s	0.0s	☆
P8-51	Sleep frequency	0.00Hz~Wake up frequency (P8-49)	0.00Hz	☆
P8-52	sleep delay time	0.0s~6500.0s	0.0s	☆

This group of parameters is used to implement sleep and wake-up functions in water supply applications.

During the operation of the inverter, when the set frequency is less than or equal to the sleep frequency of P8-51, after the delay time of P8-52, the inverter enters the sleep state and automatically stops.

If the inverter is in the dormant state and the current running command is valid, when the set frequency is greater than or equal to the wake-up frequency of P8-49, the inverter will start after the delay time of P8-50.

In general, please set the wake-up frequency to be greater than or equal to the sleep frequency. If both the wake-up frequency and the sleep frequency are set to 0.00Hz, the sleep and wake-up functions are invalid.

When the sleep function is enabled, if the frequency setting uses the PID, whether the PID is operated in the sleep state is affected by the function code PA-28. At this time, the operation when the PID is stopped must be selected (PA-28=1).

Par.	Designation	Scope	Default	Attr
P8-53	Arrival time of this run	0.0~6500.0 minutes	0.0Min	☆
P8-54	Output power correction factor	0.00%0.00%~200.0%	100.00%	☆

When the running time of this start reaches this time, the multi-function digital DO of the inverter outputs the ON signal of "this running time is reached".

Group P9: Protection Parameters

Par.	Designation	Scope	Default	Attr
P9-00	Motor overload protection selection	0~1	1	☆
P9-01	Motor overload protection gain	0.20~10.00	1	☆

P9-00=1: At this time, the inverter judges whether the motor is overloaded according to the motor overload protection inverse time curve.

The shortest time to report motor overload is 2 minutes. If you need to adjust the motor overload current and time, please set P9-01 (motor overload protection gain). The motor overload current and overload time curves are shown in the following figure:

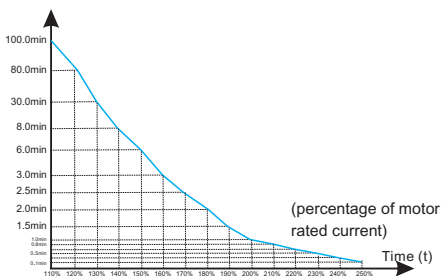

Figure 6-24. Overload current and overload time curve

For example :

if the motor needs to run at 120% motor current for 30 minutes to report overload, first calculate the motor current I_x for 30 minutes of overload under the default setting.

It can be known from the motor overload curve diagram that the 30-minute overload is within the current range of 125% and 135%, and the default setting of the 30-minute overload motor current I_x is as follows:

$$(40-30) \div (125\% - I_x) = (40-15) \div (125\% - 135\%)$$

The motor current $I_x = 129\%$ is obtained, so it can be concluded that the motor needs to report overload for 30 minutes under the condition of 120% motor current, and the motor overload protection gain is:

$$P9-01 = 120\% \div I_x = 120\% \div 129\% = 0.93$$

The user needs to correctly set the value of P9-01 according to the actual overload capacity of the motor. If this parameter is set too large, it will easily lead to the motor overheating and damage, and the inverter will not alarm!

Par.	Designation	Scope	Default	Attr
P9-02	Motor overload warning factor	50%~100%	80%	☆

This function is used to give an early warning signal to the control system through DO before motor overload fault protection. This warning factor is used to determine how much warning is given before motor overload protection. The larger the value is, the smaller the early warning is.

When the cumulative output current of the inverter is greater than the product of the overload inverse time limit curve and P9-02, the multi-function digital DO of the inverter outputs the ON signal of "motor overload pre-alarm".

Par.	Designation	Scope	Default	Attr
P9-03	Overvoltage Stall Gain	0~100	30	☆
P9-04	Overvoltage stall protection voltage	650V~800V	720V	☆

During the deceleration process of the inverter, when the DC bus voltage exceeds the overvoltage stall protection voltage, the inverter stops decelerating to maintain the current operating frequency, and continues to decelerate after the bus voltage drops.

Overvoltage stall gain, used to adjust the inverter's ability to suppress overvoltage during deceleration. The larger the value, the stronger the overvoltage suppression capability. Under the premise of no overvoltage, the smaller the gain setting, the better.

For loads with small inertia, the overvoltage stall gain should be small, otherwise the dynamic response of the system will be slowed down. For loads with large inertia, this value should be large, otherwise the suppression effect will not be good, and an overvoltage fault may occur.

When the overvoltage stall gain is set to 0, the overvoltage stall function is canceled.

Par.	Designation	Scope	Default	Attr
P9-07	Short-circuit protection selection to ground	0~1	1	☆

When the inverter is powered on, it can be selected to detect whether the motor is short-circuited to ground.

If this function is valid, the UVW terminal of the inverter will have voltage output for a period of time after power-on.

Par.	Designation	Scope	Default	Attr
P9-09	Fault automatic reset times	0~20	0	☆

When the inverter selects fault automatic reset, it is used to set the number of automatic resets. After this number of times, the inverter remains in the fault state.

Par.	Designation	Scope	Default	Attr
P9-10	Fault DO action selection during fault automatic reset	0~1	0	☆

If the inverter is set with the function of automatic fault reset, during the period of automatic fault reset, whether the fault DO acts or not can be set through P9-10.

Par.	Designation	Scope	Default	Attr
P9-11	Fault automatic reset waiting time	0.1s~100.0s	1.0s	☆

The waiting time from the inverter fault alarm to the automatic fault reset.

Par.	Designation	Scope	Default	Attr
P9-12	Input phase loss\contactor pick-up protection selection	0~1	1.0s	☆

Select whether to protect the input phase loss.

Par.	Designation	Scope	Default	Attr
P9-13	Output phase loss protection selection	0~1	11	☆

Select whether to protect the output phase loss. If you choose 0 and the output phase loss actually occurs, no fault will be reported. At this time, the actual current is larger than the current displayed on the panel, and there is a risk. Use with caution.

Par.	Designation	Scope	Default	Attr
P9-14	Type of first failure	0~55	-	●
P9-15	Second fault type		-	●
P9-16	Third (most recent) failure type		-	●

Record the last three fault types of the inverter, 0 means no fault. For the possible causes and solutions of each fault code, please refer to the relevant instructions in Chapter 7.

Par.	Designation	Scope	Default	Attr
P9-17	Frequency at the third (most recent) failure	-	-	●
P9-18	Current at the third (most recent) fault	-	-	●
P9-19	Bus voltage at the third (most recent) fault	-	-	●
P9-20	Input terminal status at the third (last) fault	-	-	●
P9-21	Output terminal status at the third (latest) fault	-	-	●
P9-22	Inverter status at the third (last) fault	-	-	●
P9-23	Power-on time at the third (most recent) fault	-	-	●
P9-24	Uptime on third (most recent) failure	-	-	●
P9-27	Frequency at second failure	-	-	●
P9-28	Current at the second fault	-	-	●
P9-29	Bus voltage at the second fault	-	-	●
P9-30	Input terminal status at the second fault	-	-	●
P9-31	Output terminal status at the second fault	-	-	●
P9-32	Inverter status at the second fault	-	-	●
P9-33	Power-on time at the second fault	-	-	●

Par.	Designation	Scope	Default	Attr
P9-34	Operating time at second failure	-	-	●
P9-37	Frequency at first failure	-	-	●
P9-38	Current at first fault	-	-	●
P9-39	Bus voltage at first fault	-	-	●
P9-40	Input terminal status at the first fault	-	-	●
P9-41	Output terminal status at the first fault	-	-	●
P9-42	Inverter status at first fault	-	-	●
P9-43	Power-on time at first fault	-	-	●
P9-44	Uptime at first failure	-	-	●
P9-47	Fault protection action selection 1	0~2	0	☆
P9-48	Fault protection action selection 2	Ones place: 0 Tens place: 0~1 Hundreds place: 0~1 Thousands: Motor overheated Ten thousand: the running time arrives	0	☆
P9-49	Fault protection action selection 3	Ones place: 0~2 Tens place: 0~2 Hundreds place: 0~2 Thousands: 0~2 Ten thousand: 0~2	0	☆
P9-50	Fault protection action selection 4	Ones place: 0~2 Tens place: Motor overspeed Hundreds place: wrong initial position	0	☆

When "free stop" is selected, the inverter will display the fault code and stop directly.

When "stop by stop mode" is selected: the inverter will display the fault code, and stop by the stop mode, and display the fault code after the stop.

When "continue running" is selected: the inverter continues to run and displays the fault code, and the running frequency is set by P9-54.

Par.	Designation	Scope	Default	Attr
P9-54	Continue to run frequency selection in case of failure	0: Run at the current operating frequency 1: Run at the set frequency 2: Run at the upper limit frequency 3: Run at the lower frequency limit 4: Running at abnormal standby frequency	-	☆
P9-55	Second Frequency Converter Status	0.0%~100.0% (100.0% corresponds to the maximum frequency A0-10)	100.00%	☆

When a fault occurs during the operation of the inverter, and the processing mode of the fault is set to continue running, the inverter displays the fault code and runs at the frequency determined by P9-54.

When the abnormal standby frequency is selected to run, the value set by P9-55 is the percentage relative to the maximum frequency.

Par.	Designation	Scope	Default	Attr
P9-56	Second power-on time	0~2	0	☆
P9-57	Second run time	0°C~200°C	110°C	☆
P9-58	Frequency at first failure	0°C~200°C	90°C	☆

The temperature signal of the motor temperature sensor needs to be connected to the multi-function input and output expansion card, which is an optional accessory.

Par.	Designation	Scope	Default	Attr
P9-59	Current at first fault	0~2	0	★
P9-60	Instantaneous power failure and non-stop recovery of voltage	80%~100%	85%	★
P9-61	Instantaneous power failure and non-stop voltage recovery judgment time	0.0~100.0s	0.5s	★
P9-62	Instantaneous stop and non-stop action voltage	60%~100%	80%	★

Chapter 6 Detailed function description

This function means that in the event of an instant power failure or a sudden drop in voltage, the inverter reduces the output speed to compensate for the decrease in the DC bus voltage of the inverter by reducing the output speed, so as to keep the inverter running.

If P9-59=1, the inverter will decelerate when the power is cut off or the voltage suddenly drops, and when the bus voltage returns to normal, the inverter will accelerate to the set frequency and run normally. The basis for judging that the bus voltage is back to normal is that the bus voltage is normal and the duration exceeds the time set by P9-61.

If P9-59=2, the inverter will decelerate until it stops when the power is cut off or the voltage suddenly drops.

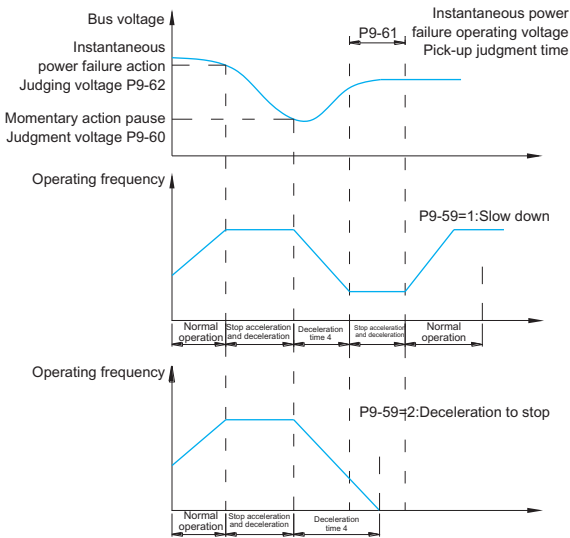

Fig.6-25 Schematic diagram of instantaneous power failure

Par.	Designation	Scope	Default	Attr
P9-63	Drop load protection option	0~1	0	☆
P9-64	Load drop detection level	0.0~100.0%	10.00%	☆
P9-65	Load drop detection time	0.0~60.0s	1.0S	☆

If the load loss protection function is valid, when the output current of the inverter is less than the load loss detection level P9-64, and the duration is longer than the load loss detection time P9-65, the output frequency of the inverter is automatically reduced to 7% of the rated frequency. During the load loss protection period, if the load recovers, the inverter will automatically resume to run at the set frequency.

Par.	Designation	Scope	Default	Attr
P9-67	Overspeed detection value	0.0%~50.0% (maximum frequency)	20.00%	☆
P9-68	Overspeed detection time	0.0s: no detection 0.1~60.0s	1.0S	☆

This function is only valid when the inverter is running in closed-loop vector control.

When the inverter detects that the actual speed of the motor exceeds the set frequency, the excess value is greater than the over-speed detection value P9-67, and the duration is longer than the over-speed detection time P9-68, the inverter fault alarm OSE, and according to the fault protection action mode deal with.

Par.	Designation	Scope	Default	Attr
P9-69	Excessive speed deviation detection value	0.0%~50.0% (maximum frequency)	20.00%	☆
P9-70	Excessive speed deviation detection time	0.0s: no detection 0.1~60.0s	5.0S	☆

This function is only valid when the inverter is running in closed-loop vector control.

When the inverter detects that there is a deviation between the actual speed of the motor and the set frequency, the deviation is greater than the excessive speed deviation detection value P9-69, and the duration is longer than the excessive speed deviation detection time P9-70, the inverter fault alarm dEuF, And deal with it according to the fault protection action mode.

When the excessive speed deviation detection time is 0.0s, the excessive speed deviation fault detection will be canceled.

Group PA: Process PID

PID control is a common method of process control. By performing proportional, integral and differential operations on the difference between the feedback signal of the controlled variable and the target signal, and by adjusting the output frequency of the inverter, a closed-loop system is formed, so that the controlled variable is stable at target value.

It is suitable for process control occasions such as flow control, pressure control and temperature control. Figure 6-25 is the control principle block diagram of process PID.

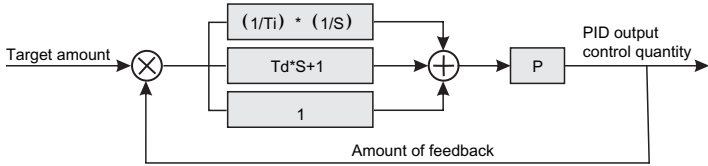

Fig.6-26 Process PID block diagram

Par.	Designation	Scope	Default	Attr
PA-00	PID setting	0~6	0	☆
PA-01	PID digital setting	0.0%~100.0%	50.0%	☆

This parameter is used to select the target quantity given channel of the process PID.

The set target value of the process PID is a relative value, and the setting range is 0.0% to 100.0%. Similarly, the feedback quantity of PID is also a relative quantity, and the function of PID is to make these two relative quantities the same.

Par.	Designation	Scope	Default	Attr
PA-02	PID feedback	0~8	0	☆

This parameter is used to select the feedback signal channel for the process PID.

The feedback amount of the process PID is also a relative value, and the setting range is 0.0% to 100.0%.

Par.	Designation	Scope	Default	Attr
PA-03	PID action direction	0~1	0	☆

Positive effect:

When the feedback signal of the PID is less than the given amount, the output frequency of the inverter increases. Such as winding tension control occasions.

Reaction:

When the feedback signal of the PID is less than the given amount, the output frequency of the inverter decreases. Such as unwinding tension control occasions. This function is affected by the reversal of the PID action direction of the multi-function terminal (function 35), and needs to be paid attention to during use.

Par.	Designation	Scope	Default	Attr
PA-04	PID given feedback range	0~65535	1000	☆

PID given feedback range is a dimensionless unit, used for PID given display U0-15 and PID feedback display U0-16.

The relative value of the given feedback of PID is 100.0%, corresponding to the given feedback range PA-04. For example, if PA-04 is set to 2000, then when the PID given is 100.0%, the PID given display U0-15 is 2000.

Par.	Designation	Scope	Default	Attr
PA-05	Proportional gain Kp1	0.0~1000.0	50.0	☆
PA-06	Integration time Ti1	0.01s~10.00s	2.00s	☆
PA-07	Derivative time Td1	0.000s~10.000s	0.000s	☆

Proportional gain Kp1:

Determines the adjustment strength of the entire PID regulator, the greater the Kp1, the greater the adjustment strength. The parameter 100.0 indicates that when the deviation between the PID feedback amount and the given amount is 100.0%, the adjustment range of the PID regulator to the output frequency command is the maximum frequency.

Integration time Ti1:

Determines the strength of the PID regulator integral adjustment. The shorter the integration time, the stronger the adjustment intensity. The integral time means that when the deviation between the PID feedback quantity and the given quantity is 100.0%, the integral regulator continuously adjusts after this time, and the adjustment quantity reaches the maximum frequency.

Differential time Td1:

Determines how strongly the PID regulator adjusts the deviation rate of change. The longer

the differentiation time, the greater the adjustment intensity. Differential time means that when the feedback amount changes 100.0% within this time, the adjustment amount of the differential regulator is the maximum frequency.

Par.	Designation	Scope	Default	Attr
PA-08	Cutoff FREQ when opposite to rotary set direction	0.00Hz~maximum FREQ	0.00Hz	★

In some cases, only when the PID output frequency is negative (that is, the inverter is reversed), can the PID control the given amount and the feedback amount to the same state, but too high reverse frequency is not allowed in some occasions. Yes, PA-08 is used to determine the upper limit of the reverse frequency.

Par.	Designation	Scope	Default	Attr
PA-09	PID offset limit	0.0%~100.0%	0.0%	☆

When the deviation between the PID given amount and the feedback amount is less than PA-09, the PID will stop adjusting. In this way, when the deviation between the given and the feedback is small, the output frequency is stable and unchanged, which is very effective for some closed-loop control occasions.

Par.	Designation	Scope	Default	Attr
PA-10	PID derivative limit	0.0%~100.0%	0.10%	☆

In the PID regulator, the role of differential is more sensitive, and it is easy to cause system oscillation. For this reason, the role of PID differential is generally limited to a small range. PA-10 is used to set the range of PID differential output.

Par.	Designation	Scope	Default	Attr
PA-11	Filtering time of PID setting	0.00~650.00s	0.00s	☆

PID given change time, refers to the time required for PID given value to change from 0.0% to 100.0%.

When the PID given changes, the PID given value changes linearly according to the given change time to reduce the adverse effect of the given sudden change on the system.

Par.	Designation	Scope	Default	Attr
PA-12	Filtering time of PID feedback	0.00s~60.00s	0.00s	☆
PA-13	Filtering time of PID output	0.00s~60.00s	0.00s	☆

PA-12 is used to filter the PID feedback amount, which is beneficial to reduce the influence of the feedback amount by interference, but it will bring the response performance of the process closed-loop system.

PA-13 is used to filter the PID output frequency. This filter will weaken the sudden change of the output frequency of the inverter, but it will also bring the response performance of the process closed-loop system.

Par.	Designation	Scope	Default	Attr
PA-14	Reserved	-	-	-
PA-15	Proportional gain Kp2	0.0~1000.0	20	☆
PA-16	Integration time Ti2	0.01s~10.00s	2.00s	☆
PA-17	Derivative time Td2	0.000s~10.000s	0.000s	☆
PA-18	PID parameter switch	0~3	0	☆
PA-19	PID parameter switching deviation 1	0.0%~PA-20	20.0%	☆
PA-20	PID parameter switching deviation 2	PA-19~100.0%	80.0%	☆

In some applications, a set of PID parameters cannot meet the needs of the entire running process, and different PID parameters need to be used in different situations.

This group of function codes is used for switching between two groups of PID parameters. The setting method of the regulator parameters PA-15~PA-17 is similar to the parameters PA-05~PA-07.

The two groups of PID parameters can be switched through the multi-function digital DI terminal, and can also be switched automatically according to the PID deviation. When the multi-function DI terminal switching is selected, the function selection of the multi-function terminal should be set to 43 (PID parameter switching terminal). 2 (PA-15~PA-17).

When automatic switching is selected, when the absolute value of the deviation between reference and feedback is less than PID parameter switching deviation 1 (PA-19), the PID parameter selects parameter group 1. When the absolute value of deviation between reference and feedback is greater than PID switching deviation 2 (PA-20), PID parameter selection selects parameter group 2. When the deviation between reference and feedback is between

switching deviation 1 and switching deviation 2, the PID parameters are linear interpolation values of two sets of PID parameters, as shown in Figure 7-26.

Par.	Designation	Scope	Default	Attr
PA-12	Filtering time of PID feedback	0.00s~60.00s	0.00s	☆
PA-13	Filtering time of PID output	0.00s~60.00s	0.00s	☆
PA-14	Reserved	-	-	-
PA-15	Proportional gain Kp2	0.0~1000.0	20	☆
PA-16	Integration time Ti2	0.01s~10.00s	2.00s	☆
PA-17	Derivative time Td2	0.000s~10.000s	0.000s	☆
PA-18	PID parameter switch	0~3	0	☆
PA-19	PID parameter switching deviation 1	0.0%~PA-20	20.0%	☆
PA-20	PID parameter switching deviation 2	PA-19~100.0%	80.0%	☆

PA-12 is used to filter the PID feedback amount, which is beneficial to reduce the influence of the feedback amount by interference, but it will bring the response performance of the process closed-loop system.

PA-13 is used to filter the PID output frequency. This filter will weaken the sudden change of the output frequency of the inverter, but it will also bring the response performance of the process closed-loop system.

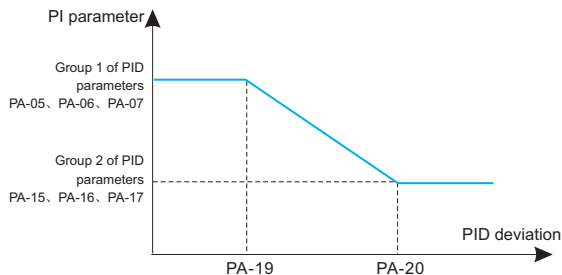

Fig.6-27 PID parameter switching

Par.	Designation	Scope	Default	Attr
PA-21	PID initial value	0.0%~100.0%	0.0%	☆
PA-22	PID initial value holding time	0.00~650.00s	0.0s	☆

When the inverter starts, the PID output is fixed at the PID initial value PA-21, and the PID starts the closed-loop adjustment operation after the PID initial value holding time PA-22 is continued.

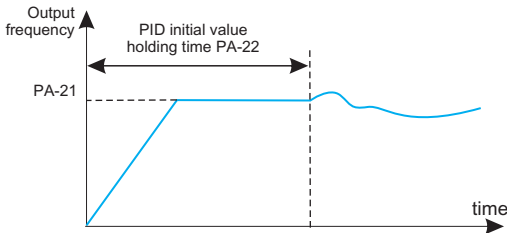

Fig.6-28 Schematic diagram of PID initial value function

Par.	Designation	Scope	Default	Attr
PA-12	Filtering time of PID feedback	0.00s~60.00s	0.00s	☆
PA-13	Filtering time of PID output	0.00s~60.00s	0.00s	☆

This function is used to limit the difference between two beats (2ms/beat) of PID output, so as to restrain the PID output from changing too fast and make the inverter run more stable.

Par.	Designation	Scope	Default	Attr
PA-23	Reserve	-	-	-
PA-24	Reserve	-	-	-

Reserve.

Par.	Designation	Scope	Default	Attr
PA-25	PID integral properties	Units:0~1 Tens place: 0~1	0	☆

Separation of points:

If the integral separation is set to be valid, when the multi-function digital DI integral pause (function 22) is valid, the integral PID integral of the PID stops operation, and only the proportional and differential functions of the PID are valid at this time.

When the integral separation selection is invalid, regardless of whether the multi-function digital DI is valid or not, the integral separation is invalid.

Whether to stop the integration after the output reaches the limit:

After the PID operation output reaches the maximum or minimum value, you can choose whether to stop the integral action. If you choose to stop the integration, the PID integration will stop calculating at this time, which may help reduce the overshoot of the PID.

Par.	Designation	Scope	Default	Attr
PA-26	PID feedback loss detection value	0.0%: Not judged feedback loss 0.1%~100.0%	0.0%	☆
PA-27	PID feedback loss detection time	0.0s~20.0s	0.0s	☆

This function code is used to judge whether the PID feedback is lost.

When the PID feedback amount is less than the feedback loss detection value PA-26, and the duration exceeds the PID feedback loss detection time PA-27, the inverter will alarm the fault PIdE, and handle it according to the selected fault handling method.

Par.	Designation	Scope	Default	Attr
PA-28	PID shutdown operation	0~1	0	☆

It is used to select whether the PID continues to operate in the PID stop state. In general applications, the PID should stop computing in the stop state.

Group PB: Fixed length counting parameter

The swing frequency function is suitable for textile, chemical fiber and other industries, as well as occasions where traversing and winding functions are required.

The swing frequency function refers to the output frequency of the inverter, which swings up and down with the set frequency as the center. The trajectory of the running frequency on the time axis is shown in Figure 7-29. The swing amplitude is set by PB-00 and PB-01. When PB-01 is set to 0, the swing is 0, and the swing frequency does not work.

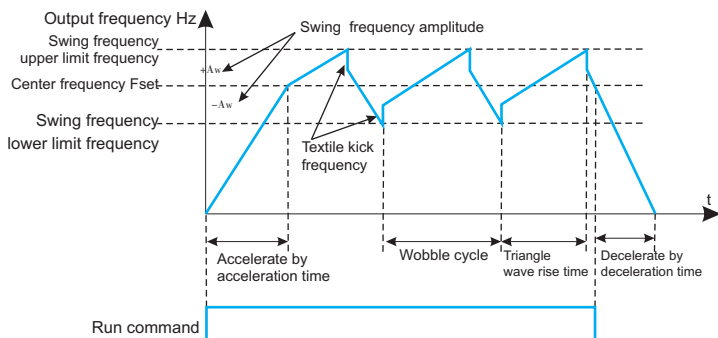

Figure 6-29. Schematic diagram of swing frequency operation

Par.	Designation	Scope	Default	Attr
PB-05	Set length	0m~65535m	1000m	☆
PB-06	Actual length	0m~65535m	0m	☆
PB-07	Pulses per meter	0.1~6553.5	100	☆

The above function codes are used for fixed-length control.

The length information needs to be collected through the multi-function digital input terminal. The number of pulses sampled by the terminal is divided by the number of pulses per meter PB-07, and the actual length PB-06 can be calculated. When the actual length is greater than the set length PB-05, the multi-function digital DO outputs the "length reached" ON signal.

During the fixed-length control process, the length reset operation can be performed through the multi-function DI terminal (the DI function selection is 28). For details, please refer to P4-00~P4-09.

In the application, the corresponding input terminal function needs to be set to "length count input" (function 27). When the pulse frequency is high, the DI5 port must be used.

Par.	Designation	Scope	Default	Attr
PB-08	Set count value	1~65535	1000	☆
PB-09	Specify count value	1~65535	1000	☆

The count value needs to be collected through the multi-function digital input terminal. In the application, the corresponding input terminal function needs to be set to "counter input" (function 25). When the pulse frequency is high, the DI5 port must be used.

When the count value reaches the set count value PB-08, the multi-function digital DO outputs the "set count value reached" ON signal, and then the counter stops counting.

When the count value reaches the designated count value PB-09, the multi-function digital DO outputs the "designated count value reached" ON signal, and the counter continues to count at this time, and the counter stops until the "set count value".

The specified count value PB-09 should not be greater than the set count value PB-08.

Figure 6-30 is a schematic diagram of the function of setting count value arrival and specifying count value arrival.

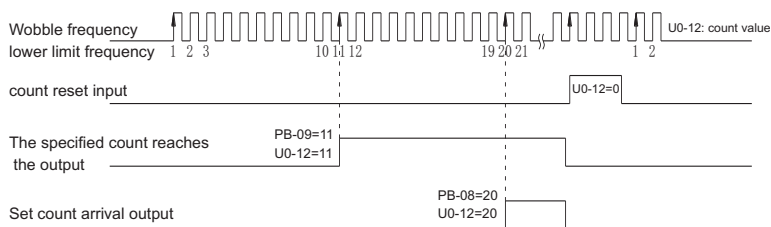

Fig.6-30 Schematic diagram of set count value given and specified count value given

Group PC: Multi-segment instructions, simple PLC

The multi-stage command of the inverter has more functions than the usual multi-stage speed. In addition to realizing the multi-stage speed function, it can also be used as the voltage setting of the V/F separation and the given setting of the process PID. For this reason, the dimensions of multi-segment instructions are relative.

The program running function is different from the user programmable function of the inverter, and the program running can only complete the simple combined operation of multi-segment instructions. The user programmable functions are more abundant and practical, please refer to the relevant instructions of the A7 group.

Par.	Designation	Scope	Default	Attr
PC-00	Multiband frequency 0	-100.0%~100.0%	0.00%	☆
PC-01	Multiband frequency 1	-100.0%~100.0%	0.00%	☆
PC-02	Multiband frequency 2	-100.0%~100.0%	0.00%	☆
PC-03	Multiband frequency 3	-100.0%~100.0%	0.00%	☆
PC-04	Multiband frequency 4	-100.0%~100.0%	0.00%	☆
PC-05	Multiband frequency 5	-100.0%~100.0%	0.00%	☆
PC-06	Multiband frequency 6	-100.0%~100.0%	0.00%	☆
PC-07	Multiband frequency 7	-100.0%~100.0%	0.00%	☆
PC-08	Multiband frequency 8	-100.0%~100.0%	0.00%	☆
PC-09	Multiband frequency 9	-100.0%~100.0%	0.00%	☆
PC-10	Multiband frequency 10	-100.0%~100.0%	0.00%	☆
PC-11	Multiband frequency 11	-100.0%~100.0%	0.00%	☆
PC-12	Multiband frequency 12	-100.0%~100.0%	0.00%	☆
PC-13	Multiband frequency 13	-100.0%~100.0%	0.00%	☆
PC-14	Multiband frequency 14	-100.0%~100.0%	0.00%	☆
PC-15	Multiband frequency 15	-100.0%~100.0%	0.00%	☆

Multi-segment instructions can be used in three occasions: as frequency setting, as voltage setting for V/F separation, and as process PID setting.

The multi-segment instruction needs to be switched according to the different states of the multi-function digital DI. For details, please refer to the relevant instructions of the P4 group.

Par.	Designation	Scope	Default	Attr
PC-16	Simple PLC operation mode	0~2	0	☆

The program running function has two functions: as frequency setting or as voltage setting for V/F separation.

Figure 6-31 is a schematic diagram of the program running as the frequency setting. When the program running is used as the frequency setting, the positive and negative values of PC-00~PC-15 determine the running direction. If it is negative, it means that the inverter runs in the opposite direction.

Par.	Designation	Scope	Default	Attr
PC-16	Simple PLC operation mode	0~2	0	☆

The program running function has two functions: as frequency setting or as voltage setting for V/F separation.

Figure 6-31 is a schematic diagram of the program running as the frequency setting. When the program running is used as the frequency setting, the positive and negative values of PC-00~PC-15 determine the running direction. If it is negative, it means that the inverter runs in the opposite direction.

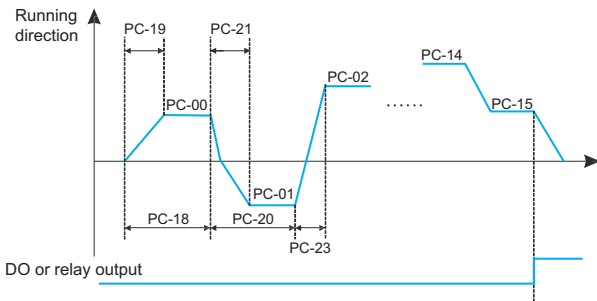

Fig.6-31 Simple PLC schematic diagram

When used as frequency setting, PLC has three operation modes, when used as V/F separation voltage setting, it does not have these three modes. in:

0: Stop at the end of a single operation

The inverter will automatically stop after completing a single cycle, and it needs to give the running command again to start.

- 1: Keep the final value at the end of a single operation After the inverter completes a single cycle, it will automatically keep the running frequency and direction of the last segment.
- 2: Continuous cycle After the inverter completes one cycle, it will automatically start the next cycle until it stops when there is a stop command.

Par.	Designation	Scope	Default	Attr
PC-17	Simple PLC power-down memory selection	Ones place: power-down memory selection 0: no memory when power off Tens place: stop memory selection 0: no memory when stopped 1: Power-down memory 2: Stop memory	0	☆

PLC power-off memory means to memorize the PLC's running stage and running frequency before power-off, and continue to run from the memory stage when the power is next turned on. If you choose not to memorize, the PLC process will be restarted every time the power is turned on.

The PLC shutdown memory is to record the previous PLC running stage and running frequency when it stops, and continue to run from the memory stage in the next running. Choose not to memorize to restart the PLC process each time it is started.

Par.	Designation	Scope	Default	Attr
PC-18	Simple PLC section 0 running time	0.0s(h)~6553.5s(h)	0.0s(h)	☆
PC-19	Simple PLC section 0 acceleration and deceleration time selection	0~3	0	☆
PC-20	Simple PLC section 1 running time	0.0s(h)~6553.5s(h)	0.0s(h)	☆
PC-21	Simple PLC section 1 acceleration and deceleration time selection	0~3	0	☆
PC-22	Simple PLC section 2 running time	0.0s(h)~6553.5s(h)	0.0s(h)	☆
PC-23	Simple PLC section 2 acceleration and deceleration time selection	0~3	0	☆
PC-24	Simple PLC section 3 running time	0.0s(h)~6553.5s(h)	0.0s(h)	☆
PC-25	Simple PLC section 3 acceleration and deceleration time selection	0~3	0	☆
PC-26	Simple PLC section 4 running time	0.0s(h)~6553.5s(h)	0.0s(h)	☆

Par.	Designation	Scope	Default	Attr
PC-27	Simple PLC section 4 acceleration and deceleration time selection	0~3	0	☆
PC-28	Simple PLC section 5 running time	0.0s(h)~6553.5s(h)	0.0s(h)	☆
PC-29	Simple PLC section 5 acceleration and deceleration time selection	0~3	0	☆
PC-30	Simple PLC section 6 running time	0.0s(h)~6553.5s(h)	0.0s(h)	☆
PC-31	Simple PLC section 6 acceleration and deceleration time selection	0~3	0	☆
PC-32	Simple PLC section 7 running time	0.0s(h)~6553.5s(h)	0.0s(h)	☆
PC-33	Simple PLC section 7 acceleration and deceleration time selection	0~3	0	☆
PC-34	Simple PLC section 8 running time	0.0s(h)~6553.5s(h)	0.0s(h)	☆
PC-35	Simple PLC section 8 acceleration and deceleration time selection	0~3	0	☆
PC-36	Simple PLC section 9 running time	0.0s(h)~6553.5s(h)	0.0s(h)	☆
PC-37	Simple PLC section 9 acceleration and deceleration time selection	0~3	0	☆
PC-38	Simple PLC section 10 running time	0.0s(h)~6553.5s(h)	0.0s(h)	☆
PC-39	Simple PLC section 10 acceleration and deceleration time selection	0~3	0	☆
PC-40	Simple PLC section 11 running time	0.0s(h)~6553.5s(h)	0.0s(h)	☆
PC-41	Simple PLC section 11 acceleration and deceleration time selection	0~3	0	☆
PC-42	Simple PLC section 12 running time	0.0s(h)~6553.5s(h)	0.0s(h)	☆
PC-43	Simple PLC section 12 acceleration and deceleration time selection	0~3	0	☆
PC-44	Simple PLC section 13 running time	0.0s(h)~6553.5s(h)	0.0s(h)	☆
PC-45	Simple PLC section 13 acceleration and deceleration time selection	0~3	0	☆
PC-46	Simple PLC section 14 running time	0.0s(h)~6553.5s(h)	0.0s(h)	☆
PC-47	Simple PLC section 14 acceleration and deceleration time selection	0~3	0	☆
PC-48	Simple PLC section 15 running time	0.0s(h)~6553.5s(h)	0.0s(h)	☆

Par.	Designation	Scope	Default	Attr
PC-49	Simple PLC section 15 acceleration and deceleration time selection	0~3	0	☆
PC-50	Simple PLC running time unit	0~1	0	☆
PC-51	Simple PLC running time unit	0~6	0	☆

This parameter determines the given channel of multi-segment instruction 0.

In addition to PC-00, there are many other options for multi-segment instruction 0, which is convenient to switch between multi-short instructions and other given methods. When the multi-segment command is used as the frequency setting or the program operation is used as the frequency setting, the switching between the two frequency settings can be easily realized.

Group PD: MODBUS Communication Parameters

Please refer to "Communication Agreement"

Group PP: Function code management

If PP-00 sets any non-zero number, the password protection function will take effect. The next time you enter the menu, you must enter the correct password, otherwise you cannot view and modify the function parameters, please keep in mind the set user password.

Setting PP-00 to 00000 will clear the set user password and make the password protection function invalid.

Par.	Designation	Scope	Default	Attr
PP-01	Parameter initialization	0~05	0	★

1. Restore factory settings, excluding motor parameters

After setting PP-01 to 1, most of the functional parameters of the inverter are restored to the factory default parameters, but the motor parameters, frequency command decimal point (P0-22), fault record information, cumulative running time (P7-09), cumulative power-on Time (P7-13) and cumulative power consumption (P7-14) do not recover.

2. Clear record information

Clear the inverter fault record information, accumulated running time (P7-09), accumulated power-on time (P7-13), and accumulated power consumption (P7-14).

3. Backup user's current parameters

Back up the parameters set by the current user. Back up the setting values of all current function parameters. In order to facilitate customers to recover after parameter adjustment disorder.

4. Restore user backup parameters

Restore the user parameters backed up before, that is, restore the parameters backed up by setting PP-01 to 05.

Par.	Designation	Scope	Default	Attr
PP-02	Function parameter group display selection	Ones place: 0~1 Tens place:0~1	11	☆
PP-03	Personality parameter group display selection	Ones place: 0~1 Tens place:0~1	0	☆
PP-04	Function code modification attribute	0~1	0	☆

Whether the function code parameters set by the user can be modified is used to prevent the danger of the function parameters being changed by mistake.

When this function code is set to 0, all function codes can be modified; and when it is set to 1, all function codes can only be viewed and cannot be modified.

Group A0: Torque Control Parameters

Par.	Designation	Scope	Default	Attr
A0-00	Speed/torque control mode selection	0~1	0	★

Used to select the inverter control mode: speed control or torque control.

The multi-function digital DI terminal has two functions related to torque control: torque control prohibition (function 29), speed control/torque control switching (function 46). These two terminals should be used in conjunction with A0-00 to realize the switching between speed and torque control.

When the speed control/torque control switching terminal is invalid, the control mode is determined by A0-00. If the speed control/torque control switching is valid, the control mode is equivalent to the inversion of the value of A0-00. In any case, when the torque control prohibition terminal is valid, the inverter is fixed in the speed control mode.

Par.	Designation	Scope	Default	Attr
A0-01	Torque setting selection in torque control mode	0~7	0	★
A0-03	Torque digital setting in torque control mode	-200.0%~200.0%	150.00%	☆

A0-01 is used to select torque setting, there are 8 torque setting modes.

Torque setting adopts relative value, 100.0% corresponds to the rated torque of the inverter. The setting range is -200.0% to 200.0%, indicating that the maximum torque of the inverter is twice the rated torque of the inverter.

When torque setting adopts modes 1 to 7, 100% of communication, analog input and pulse input correspond to A0-03.

Par.	Designation	Scope	Default	Attr
A0-05	Torque control forward maximum frequency	0.00Hz~Maximum frequency	50.00Hz	☆
A0-06	Torque control reverse maximum frequency	0.00Hz~Maximum frequency	50.00Hz	☆

It is used to set the forward or reverse maximum running frequency of the inverter in torque control mode.

When the inverter torque is controlled, if the load torque is less than the motor output torque, the motor speed will continue to rise. In order to prevent accidents such as flying in the mechanical system, the maximum motor speed during torque control must be limited.

Par.	Designation	Scope	Default	Attr
A0-07	Torque rise filter time	0.00s~65000s	0.00s	☆
A0-08	Torque drop filter time	0.00s~65000s	0.00s	☆

In the torque control mode, the difference between the motor output torque and the load torque determines the speed change rate of the motor and the load. Therefore, the motor speed may change rapidly, causing problems such as excessive noise or mechanical stress. By setting the torque control acceleration/deceleration time, the motor speed can be changed smoothly.

But for the occasions that require quick torque response, it is necessary to set the torque control acceleration and deceleration time to 0.00s.

Group A5: Control optimization parameters

Par.	Designation	Scope	Default	Attr
A5-00	DPWM switching upper limit frequency	5.00Hz~Maximum frequency	8.00Hz	☆

Only valid for VF control.

The wave-emitting mode of the asynchronous machine VF is determined. If it is lower than this value, it is a 7-segment continuous modulation mode, and on the contrary, it is a 5-segment discontinuous modulation mode.

When it is 7-stage continuous modulation, the switching loss of the inverter is large, but the current ripple is small; in the 5-stage intermittent debugging mode, the switching loss is small and the current ripple is large; but at high frequency, it may cause the instability of the motor operation generally does not need to be modified.

Par.	Designation	Scope	Default	Attr
A5-02	Dead time compensation mode selection	0~1	1	☆

This parameter generally does not need to be modified. Only when there are special requirements for the quality of the output voltage waveform, or when the motor has an abnormality such as oscillation, it is necessary to try to switch to select a different compensation mode.

Compensation mode 2 is recommended for high power.

Par.	Designation	Scope	Default	Attr
A5-03	Random PWM depth	0~10	0	☆

Setting random PWM can soften the monotonous and harsh motor sound and help reduce external electromagnetic interference. When the random PWM depth is set to 0, the random PWM is invalid. Adjusting random PWM with different depths will get different effects.

Par.	Designation	Scope	Default	Attr
A5-04	Fast current limit enable	0~1	1	☆

Enabling the fast current limiting function can minimize the overcurrent fault of the inverter and ensure the uninterrupted operation of the inverter. If the inverter continues to be in the fast current limiting state for a long time, the inverter may be damaged by overheating, which

is not allowed. Therefore, the inverter will alarm fault OCn when the inverter is rapidly limiting the current for a long time, indicating that the inverter is overloaded and needs to be stopped.

Par.	Designation	Scope	Default	Attr
A5-05	Maximum output voltage coefficient	100~110%	105%	★

It is used to set the current detection compensation of the inverter. If the setting is too large, the control performance may be degraded. Usually no modification is required.

Par.	Designation	Scope	Default	Attr
A0-06	Torque control reverse maximum frequency	0.00Hz~Maximum frequency	50.00Hz	☆

It is used to set the voltage value of the inverter's undervoltage fault Uu. The inverter of different voltage levels is 100.0%, corresponding to different voltage points, which are:

Single-phase 220V or three-phase 220V: 200V

Three-phase 380V: 350V

Three-phase 480V: 450V

Par.	Designation	Scope	Default	Attr
A5-08	low speed carrier	0.0~8.0kHz	0	☆

Adjusting this value can improve the effective utilization rate of the voltage, and if the adjustment is too small, it will easily lead to unstable system operation. User modification is not recommended.

Par.	Designation	Scope	Default	Attr
A5-09	Overvoltage point setting	200.0V~2500.0V	Model dependent	★

Used to set the voltage value of the inverter overvoltage fault

Note:

The factory default value is also the upper limit of the inverter's internal overvoltage protection. This parameter setting takes effect only when the set value of A5-09 is less than the factory default value. When it is higher than the factory value, the factory value shall prevail.

Group U0: Basic monitoring parameters

The U0 parameter group is used to monitor the operating status information of the inverter. Customers can view it through the panel to facilitate on-site debugging, and can also read the parameter group value through communication for monitoring by the host computer. Among them, U0-00 ~ U0-31 are the running and stop monitoring parameters defined in P7-03 and P7-04.

Par.	Designation	Scope	Default	Attr
U0-00	Operating frequency (Hz)	0.01Hz	7000H	
U0-01	Set frequency (Hz)	0.01Hz	7001H	

Displays the theoretical running frequency of the inverter and the absolute value of the set frequency.

See U0-19 for the actual output frequency of the inverter.

Par.	Designation	Scope	Default	Attr
U0-02	Bus voltage (V)	0.1V	7002H	

Displays the inverter bus voltage value.

Par.	Designation	Scope	Default	Attr
U0-03	Output voltage (V)	1V	7003H	

Displays the output voltage value of the inverter during operation.

Par.	Designation	Scope	Default	Attr
U0-04	Output current (A)	0.01A	7004H	

Displays the inverter output current value during operation.

Par.	Designation	Scope	Default	Attr
U0-05	Output torque (%)	0.1kW	7005H	

Displays the output power value of the inverter during operation.

Par.	Designation	Scope	Default	Attr
U0-06	Output torque (%)	0.001	7006H	

Displays the output torque value of the inverter during operation.

Par.	Designation	Scope	Default	Attr
U0-07	X input state	1	7007H	

Displays the current DI terminal input status value. After being converted into binary data, each bit corresponds to a DI input signal, 1 means that the input is a high-level signal, and 0 means that the input is a low-level signal. The corresponding relationship between each bit and the input terminal is as follows:

Bit0	Bit1	Bit2	Bit3
DI1	DI2	DI3	DI4
Bit4	Bit5	Bit6	Bit7
DI5			
Bit8	Bit9	Bit10	Bit11
		VDI1	VDI2
Bit12	Bit13	Bit14	Bit15
VDI3	VDI4	VDI5	--

Par.	Designation	Scope	Default	Attr
U0-08	DO output status	1	7008H	

Displays the current DO terminal output status value. After conversion into binary data, each bit corresponds to a DO signal, 1 means the output is high, and 0 means the output is low. The corresponding relationship between each bit and the output terminal is as follows:

Bit0	Bit1	Bit2	Bit3
	Relay 1		
Bit4	Bit5	Bit6	Bit7
DI5	VDO1	VDO2	VDO3
Bit8	Bit9	Bit10	Bit11
VDO4	VDO5		

Par.	Designation	Scope	Default	Attr
U0-10	Ai2 voltage (V)/current (mA)	0.01V/0.01mA	700AH	

When P4-40 is set to 0, Ai2 sampling data display unit is voltage (V)

When P4-40 is set to 1, Ai2 sampling data display unit is current (mA)

Par.	Designation	Scope	Default	Attr
U0-14	Load speed display	1	700EH	

The displayed value is described in P7-12.

Par.	Designation	Scope	Default	Attr
U0-15	PID setting	1	700FH	
U0-16	PID feedback	1	7010H	

Display PID set value and feedback value, the value format is as follows:

PID setting = PID setting (percentage) × PA-04

PID feedback = PID feedback (percentage) × PA-04

Par.	Designation	Scope	Default	Attr
U0-18	Input pulse frequency (Hz)	0.01kHz	7012H	

Display DI5 high-speed pulse sampling frequency, the minimum unit is 0.01KHz.

Par.	Designation	Scope	Default	Attr
U0-19	Feedback speed (Hz)	0.01Hz	7013H	

Displays the actual output frequency of the inverter.

The tens digit setting value of function code P7-12 (load speed display decimal point) represents the number of decimal points in U0-19/U0-29. When it is set to 2, the number of decimal points in U0-19 is 2, and the display range is -320.00Hz~320.00Hz; when it is set to 1, the number of decimal points in U0-19 is 1, and the display range is -500.0Hz~500.0Hz.

Par.	Designation	Scope	Default	Attr
U0-20	Remaining running time	0.1Min	7014H	

Displays the remaining running time during timing operation. For the introduction of timing operation, see the introduction of parameters P8-42~ P8-44.

Par.	Designation	Scope	Default	Attr
U0-21	Ai1 voltage before correction	0.001V	7015H	
U0-22	Ai2 Voltage (V)/Current (mA) before calibration	0.001V/0.01mA	7016H	

Displays the actual value of the analog input sampled voltage/current.

The actual voltage/current used is linearly corrected to make the deviation between the sampled voltage/current and the actual input voltage/current smaller.

See U0-09 and U0-10 for the actual correction voltage/current used, and see the AC group introduction for the correction method.

Par.	Designation	Scope	Default	Attr
U0-24	Line speed	1m/Min	7018H	

Display the linear speed of DI5 high-speed pulse sampling, the unit is: m/min.

Calculate the linear velocity value according to the actual number of sampled pulses per minute and PB-07 (pulses per meter).

Par.	Designation	Scope	Default	Attr
U0-27	input pulse frequency	1Hz	701BH	

Displays the sampling frequency of DI5 high-speed pulse in 1Hz. It is the same data as U0-18, only the displayed unit is different.

Par.	Designation	Scope	Default	Attr
U0-28	Communication settings	0.0001	701CH	

Displays the data written through the communication address 0x1000.

Par.	Designation	Scope	Default	Attr
U0-30	main frequency display	0.01Hz	701EH	

Display frequency setting main channel X frequency setting.

Par.	Designation	Scope	Default	Attr
U0-31	Auxiliary frequency display	0.01Hz	701FH	

Displays auxiliary frequency Y frequency setting.

Par.	Designation	Scope	Default	Attr
U0-39	V/F separation target voltage	1V	7027H	
U0-40	V/F split output voltage	1V	7028H	

Displays the target output voltage and the current actual output voltage when running in the V/F separation state.

For V/F separation, please refer to the related introduction of P3 group.

Par.	Designation	Scope	Default	Attr
U0-41	Intuitive display of X input status	1.00	7029H	

Visually display the DI terminal status, and its display format is as follows:

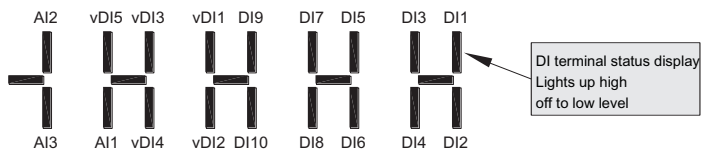

Par.	Designation	Scope	Default	Attr
U0-42	Intuitive display of Do output status	1.00	702AH	

Visually display the output status of the DO terminal, and its display format is as follows:

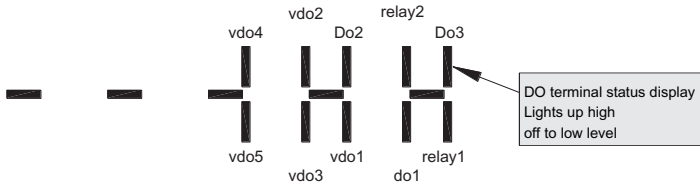

Par.	Designation	Scope	Default	Attr
U0-43	X function status visual display 1 (function 01-40)	1.00	702BH	

Visually display whether terminal functions 1 to 40 are valid

There are 5 nixie tubes on the keyboard, and each nixie tube display can represent 8 function options

The definition of digital tube is as follows:

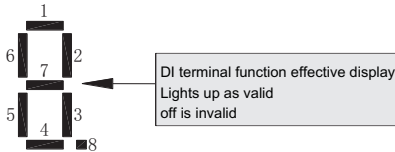

From right to left, the digital tubes represent functions 1~8, 9~16, 17~24, 25~32, 33~40 respectively.

Par.	Designation	Scope	Default	Attr
U0-44	X function status visual display 2 (functions 41-80)	1.00	702CH	

Visually display whether terminal functions 41 to 59 are valid

Display is similar to U0-43

The digital tubes represent functions 41-48, 49-56, 57-59 from right to left respectively

Par.	Designation	Scope	Default	Attr
U0-59	Set frequency (%)	0.00	703BH	
U0-60	Running frequency (%)	0.00	703CH	

Display the current set frequency and running frequency, 100.00% corresponds to the maximum frequency of the inverter (P0-10), the range is -100.00% to 100.00%.

Par.	Designation	Scope	Default	Attr
U0-61	Inverter status	1.00	703DH	
U0-62	Current fault code	1.00	703EH	

Display the inverter running status information, the data definition format is as follows:

Bit0	0: Stop; 1: Forward; 2: Reverse
Bit1	
Bit2	0: constant speed; 1: acceleration; 2: deceleration
Bit3	
Bit4	0: The bus voltage is normal; 1: Undervoltage

Chapter 7

EMC attention

7.1 EMC Definition.....	76
7.2 Introduction to EMC standards.....	76
7.3 EMC Guidance.....	76

7.1 EMC Definition

Electromagnetic compatibility refers to the ability of electrical equipment to operate in an environment of electromagnetic interference, not to interfere with the electromagnetic environment and to achieve its functions steadily.

7.2 Introduction to EMC standards

According to the national standard GB/T12668.3 requirements, products need to meet the requirements of electromagnetic interference and anti-electromagnetic interference. Our existing products implement the latest international standards: IEC/EN61800-3:2004 (Adjustable speed power drive systems part 3: EMC requirements and specific test methods), equivalent to the national standard GB/T12668.3.

IEC/EN61800-3 mainly from the electromagnetic interference and anti-electromagnetic interference two aspects of the product inspection, electromagnetic interference mainly on the product radiation interference, conduction interference and harmonic interference testing (for civilian products have this requirement). Anti-electromagnetic interference mainly on the product's conduction immunity, radiation immunity, surge immunity, rapid mutation pulse group immunity, ESD immunity and power supply low-frequency end immunity (specific test items are: 1. input voltage drop, Immunity test of interruption and change; 2. phase gap immunity test; 3. harmonic input immunity test; 4. input frequency change test; 5. input voltage imbalance test; 6. input voltage fluctuation test) test. In accordance with the above-mentioned IEC/EN61800-3 strict requirements for testing, our products in accordance with the guidance of 6.3 for installation and use, in the general industrial environment will have good electromagnetic compatibility.

7.3 EMC Guidance

7.3.1 Electromagnetic interference and installation precautions:

There are two kinds of electromagnetic interference, one is the interference of the surrounding environment electromagnetic noise to the product, the other is the interference of the product to the surrounding equipment, for the interference is relatively large occasions, it is recommended to add input reactors.

Installation considerations:

- ❶ The ground wire of products and other electrical products should be well grounded;
- ❷ Product power input and output power lines and weak electrical signal lines (e.g. control lines) as far as possible do not parallel arrangement, when conditions vertical arrangement;
- ❸ The output power line of the product is recommended to use shielded cable, or steel pipe to shield the power line, and the shield layer should be reliably grounded, for the lead of the disturbed equipment is recommended to use twisted pair shielding control line, and the shielding layer is reliably grounded;
- ❹ For motor cables longer than 100m, an output filter or reactor is required.

7.3.2 The treatment method by which the surrounding electromagnetic equipment interferes with the product:

The general cause of the electromagnetic effect on the product is the large number of relays, contactors or electromagnetic brakes installed near the product. When the product is disturbed by the wrong action, it is recommended to use the following methods to resolve:

- ❶ Add surge suppressors to devices that cause interference;
- ❷ The product input is filled with filters, specifically reference 6.3. 5 to operate;
- ❸ The product controls the signal line and the lead of the detection line with a shielded cable and securely grounds the shield.

7.3.3 How the product interferes with peripheral equipment:

There are two types of noise in this part: one is the product radiation interference, and the other is the product conduction interference. These two types of interference cause the surrounding electrical equipment to be induced by electromagnetic or static electricity. In turn, the device produced a mis-action. For several different interference situations, refer to the following methods to resolve:

- ① For measuring instruments, receivers and sensors, etc., the general signal is relatively weak, if the product is closer or in the same control cabinet, vulnerable to interference and wrong action, it is recommended to use the following methods to solve: as far away from interference sources as possible; Equally tied together, the signal line and the power line with shielded cables, and well grounded, in the output side of the product with ferric oxygen magnetic ring (select the suppression frequency in the range of 30 to 1000MHz), and around 2 to 3, For the bad situation, you can choose to add EMC output filter;
- ② Interference equipment and products using the same power supply, resulting in conduction interference, if the above methods can not eliminate interference, should be installed between the product and the power supply EMC filter (specific reference 6.3 5 to carry out the selection operation);
- ③ Peripherals are grounded separately to eliminate interference from leakage currents in the product ground wire when co-grounding.

7.3.4 Leakage current and handling:

There are two forms of leakage current when using a product: one is a ground-to-ground leakage current, and the other is a leakage current between a line and a line.

- ① Factors and solutions that affect the ground leakage current:

There is a distribution capacitor between the wire and the earth, the greater the distribution capacitor, the greater the leakage current, effectively reducing the distance between the product and the motor to reduce the distribution capacitance. The higher the carrier frequency, the greater the leakage current. The carrier frequency can be reduced to reduce leakage current. However, reducing the carrier frequency can lead to increased motor noise, please note that adding an reactor is also an effective solution to leakage current.

The leakage current increases with the increase of the circuit current, so when the motor is high, the corresponding leakage current is large.

- ② Factors and solutions that cause current leakage between lines:

There is a distribution capacitance between the product output wiring, and if the current passing through the line contains a high number of harmonics, it may cause resonance and leakage current. Using a thermal relay at this point may cause it to move incorrectly.

The solution is to reduce the carrier frequency or install the output reactor. It is recommended that the motor is not installed before the use of the appliance, using the electronic overflow protection function of the product.

7.3.4 Note that the EMC input filter is added to the power input:

- ❶ Use the filter strictly in accordance with the rating, because the filter belongs to Class I electrical appliances, the filter metal shell should be a large area with the installation cabinet metal contact is good, and requires good conductivity, otherwise there will be a risk of electric shock and seriously affect the EMC effect;
- ❷ Through EMC testing, it is found that the filter must be on the same common ground as the product PE end, otherwise the EMC effect will be seriously affected.
- ❸ The filter is installed as close as possible to the power input of the appliance.



Chapter 8

Fault Causes and Troubleshooting

8.1 Table of Fault Codes.....	82
-------------------------------	----

Once drive fault occurs, please identify the causes of fault carefully and make a detailed record of fault symptom. To seek services, please contact the dealer. Parameters U1-00, U1-09 and U1-18 are used to view the records of fault 1, fault 2 and fault 3. Faults are recorded with numeric codes (1~46), while the fault information that corresponds to each numeric fault code is specified in the table below.

8.1 Table of Fault Codes

Fault Name	Operating Panel Display	Cause	Possible Solution
Overcurrent during acceleration	Err02	Ground fault or short circuit exists in the output circuit.	◇ Check whether short-circuit occurs on the motor, motor cable or contactor.
		Control mode is SVC or FVC but motor auto-tuning is not performed.	◇ Set motor parameters according to motor nameplate and perform motor autotuning.
		Acceleration time is too short.	◇ Increase acceleration time.
		The overcurrent stall prevention parameters are set improperly.	◇ Ensure that current limit is enabled (P3-19=1). ◇ The setting of current limit level (P3-18) is too large. Adjust it between 120% and 150%. ◇ The setting of current limit gain (P3-20) is too small. Adjust it between 20 and 40.
		Customized torque boost or V/F curve is not appropriate.	◇ Adjust the customized torque boost or V/F curve.
		The spinning motor is started.	◇ Enable the flying start function or start the motor after it stops.
		The AC drive suffers external interference.	◇ View historical fault records. If the current value is far from the overcurrent level, find interference source. If external interference does not exist, it is the driver board or hall device problem.
Overcurrent during deceleration	Err03	Ground fault or short circuit exists in the output circuit.	◇ Check whether short-circuit occurs on the motor, motor cable or contactor.
		Control mode is SVC or FVC but motor auto-tuning is not performed.	◇ Set motor parameters according to motor nameplate and perform motor auto-tuning.

Fault Name	Operating Panel Display	Cause	Possible Solution
Overcurrent during deceleration	Err03	Deceleration time is too short.	<ul style="list-style-type: none"> ◇ Increase deceleration time.
		The overcurrent stall prevention parameters are set improperly.	<ul style="list-style-type: none"> ◇ Ensure that current limit is enabled (P3-19=1). ◇ The setting of current limit level (P3-18) is too large. Adjust it between 120% and 150%. ◇ The setting of current limit gain (P3-20) is too small. Adjust it between 20 and 40.
		Braking unit and braking resistor are not installed.	<ul style="list-style-type: none"> ◇ Install braking unit and braking resistor.
		The AC drive suffers external interference.	<ul style="list-style-type: none"> ◇ View historical fault records. If the current value is far from the overcurrent level, find interference source. If external interference does not exist, it is the driver board or hall device problem.
Overcurrent during deceleration	Err04	Ground fault or short circuit exists in the output circuit.	<ul style="list-style-type: none"> ◇ Check whether short-circuit occurs on the motor, motor cable or contactor.
		Control mode is SVC or FVC but motor auto-tuning is not performed.	<ul style="list-style-type: none"> ◇ Set motor parameters according to motor nameplate and perform motor auto-tuning.
		The overcurrent stall prevention parameters are set improperly.	<ul style="list-style-type: none"> ◇ Ensure that current limit is enabled (P3-19=1). ◇ The setting of current limit level (P3-18) is too large. Adjust it between 120% and 150%. ◇ The setting of current limit gain (P3-20) is too small. Adjust it between 20 and 40.
		The AC drive power class is small.	<ul style="list-style-type: none"> ◇ If output current exceeds rated motor current or rated output current of the AC drive during stable running, replace a drive of larger power class.
		The AC drive suffers external interference.	<ul style="list-style-type: none"> ◇ View historical fault records. If the current value is far from the overcurrent level, find interference source. If external interference does not exist, it is the driver board or hall device problem.

Fault Name	Operating Panel Display	Cause	Possible Solution
Overvoltage during acceleration	Err05	Input voltage is too high.	✧ Adjust input voltage to normal range.
		An external force drives motor during acceleration.	✧ Cancel the external force or install a braking resistor.
		The overvoltage stall prevention parameters are set improperly.	<ul style="list-style-type: none"> ✧ Ensure that the voltage limit function is enabled (P3-23=1). ✧ The setting of voltage limit (P3-22) is too large. Adjust it between 770 V and 700 V. ✧ The setting of frequency gain for voltage limit (P3-24) is too small. Adjust it between 30 and 50.
		Braking unit and braking resistor are not installed.	✧ Install braking unit and braking resistor.
		Acceleration time is too short.	✧ Increase acceleration time.
Overvoltage during deceleration	Err06	The overvoltage stall prevention parameters are set improperly.	<ul style="list-style-type: none"> ✧ Ensure that the voltage limit function is enabled (P3-23=1). ✧ The setting of voltage limit (P3-22) is too large. Adjust it between 770V and 700V. ✧ The setting of frequency gain for voltage limit (P3-24) is too small. Adjust it between 30 and 50.
		An external force drives motor during deceleration.	✧ Cancel the external force or install a braking resistor.
		Deceleration time is too short.	✧ Increase deceleration time.
		Braking unit and braking resistor are not installed.	✧ Install braking unit and braking resistor.
Overvoltage at constant speed	Err07	The overvoltage stall prevention parameters are set improperly.	<ul style="list-style-type: none"> ✧ Ensure that the voltage limit function is enabled (P3-23=1). ✧ The setting of voltage limit (P3-22) is too large. Adjust it between 770 V and 700 V. ✧ The setting of frequency gain for voltage limit (P3-24) is too small. Adjust it between 30 and 50. ✧ The setting of frequency rise threshold during voltage limit (P3-26) is too small. Adjust it between 5 Hz and 20 Hz.

Fault Name	Operating Panel Display	Cause	Possible Solution
Overvoltage at constant speed	Err07	An external force drives motor during running.	✧ Cancel the external force or install a braking resistor.
Control power fault	Err08	The input voltage exceeds the setting range.	✧ Adjust the input voltage to be within the setting range.
Undervoltage	Err09	Instantaneous power failure occurs	✧ Enable the power dip ride through function (P9-59≠0).
		The AC drive's input voltage is not within the permissible range.	✧ Adjust the voltage to normal range.
		The bus voltage is abnormal.	✧ Contact the agent or Inovance.
		The rectifier bridge, the buffer resistor, the driver board or the control board are abnormal.	✧ Contact the agent or Inovance.
AC drive overload	Err10	Load is too heavy or lock-rotor occurs on motor.	✧ Reduce load or check motor and mechanical conditions.
		The AC drive power class is small.	✧ Replace a drive of larger power class.
Motor overload	Err11	P9-01 (Motor overload protection gain) is set improperly.	✧ Set P9-01 correctly.
		Load is too heavy or locked rotor occurs on motor.	✧ Reduce load or check motor and mechanical conditions.
Input phase loss	Err12	Input phase loss occurs.	✧ Eliminate faults in external circuitry.
		Driver board, lightning protection board, control board, or rectifier bridge is abnormal.	✧ Contact the agent or Inovance.
Output phase loss	Err13	Motor winding is damaged.	✧ Check resistance between motor wires.
		The cable connecting the AC drive and the motor is abnormal.	✧ Check for wiring errors and ensure the output cable is connected properly.
		The AC drive's three-phase outputs are unbalanced when the motor is running.	✧ Check whether the motor three-phase winding is normal.
		The driver board or the IGBT is abnormal.	✧ Contact the agent or Inovance.

Fault Name	Operating Panel Display	Cause	Possible Solution
IGBT overheat	Err 14	The ambient temperature is too high.	✧ Lower the ambient temperature.
		The ventilation is clogged.	✧ Clean the ventilation.
		The fan is damaged.	✧ Replace the cooling fan.
		Thermally sensitive resistor of IGBT is damaged.	✧ Replace the damaged thermally sensitive resistor.
		The AC Drive IGBT is damaged.	✧ Replace the AC Drive IGBT.
External fault	Err 15	External fault signal is input through DI.	✧ Confirm that the mechanical condition allows restart (P8-18) and reset the operation.
		External fault signal is input through virtual I/O.	✧ Confirm that the virtual I/O parameters in group A1 are set correctly and reset the operation.
Communication fault	Err 16	Host controller is in abnormal state.	✧ Check the cable of host controller.
		Communication cable is abnormal.	✧ Check the communication cables.
		The serial port communication protocol (P0-28) of extension communication card is set improperly.	✧ Set P0-28 of extension communication card correctly.
		Communication parameters in group Fd are set improperly.	✧ Set communication parameters in group Fd properly.
		After all the preceding checkings are done but the fault still exists, restore the default settings.	
Contactor fault	Err 17	Driver board and power supply are abnormal.	✧ Replace driver board or power supply board.
		Contactor is abnormal.	✧ Replace contactor.
		The lightning protection board is abnormal.	✧ Replace the lightning protection board.
Current detection fault	Err 18	The hall is abnormal.	✧ Replace the hall element.
		The driver board is abnormal.	✧ Replace the driver board.

Fault Name	Operating Panel Display	Cause	Possible Solution
Motor auto-tuning fault	Err19	Motor parameters are not set according to nameplate.	✧ Set motor parameters correctly according to nameplate.
		Motor auto-tuning times out.	✧ Check the cable connecting AC drive and motor.
		The encoder is abnormal.	✧ Check whether P1-27 (encoder pulses perrevolution) is set correctly. Check whether signal lines of encoder are connected correctly and securely.
Encoder fault	Err20	Encoder is not matched.	✧ Set the type of encoder correctly.
		Encoder wiring is incorrect.	✧ Check the PG card power supply and phase sequence.
		Encoder is damaged.	✧ Replace encoder.
		PG card is abnormal.	✧ Replace PG card.
EEPROM read-write fault	Err21	The EEPROM chip is damaged.	✧ Replace the main control board.
Short circuit to ground	Err23	Motor is short circuited to the ground.	✧ Replace cable or motor.
Accumulative running time reached	Err26	Accumulative running time reaches the setting value.	✧ Clear the record through parameter initialization.
User-defined Fault 1	Err27	User-defined fault 1 is input through DI.	✧ Reset the operation.
		User-defined fault 1 is input through virtual I/O.	✧ Reset the operation.
User-defined Fault 2	Err28	User-defined fault 2 is input through DI.	✧ Reset the operation.
		User-defined fault 2 is input through virtual I/O.	✧ Reset the operation.
Accumulative power-on time reached	Err29	Accumulative power-on time reaches the setting value.	✧ Clear the record through parameter initialization.
Load loss	Err30	The output current of AC drive is smaller than F9-64 (load loss detection level).	✧ Check whether load is disconnected or the setting of P9-64 and P9-65 (load lost detection time) satisfies actual running condition.

Fault Name	Operating Panel Display	Cause	Possible Solution
PID feedback lost during running Feedback loss	Err31	PID feedback is smaller than the setting value of PA-26 (detection level of PID feedback loss).	◇ Check PID feedback or set PA-26 properly.
Pulse-by-pulse current limit fault	Err40	Load is too heavy or locked-rotor occurs on motor.	◇ Reduce load or check motor and mechanical conditions.
		The AC drive power class is small.	◇ Replace a drive of larger power class.
Motor switchover fault during running Motor winding is damaged.	Err41	Motor switchover through terminal during drive running of the AC drive.	◇ Perform motor switchover after the AC drive stops.
Speed error	Err42	Encoder parameters are set improperly.	◇ Set encoder parameters properly.
		Motor auto-tuning is not performed.	◇ Perform motor auto-tuning.
		P9-69 (detection level of speed error) and P9-70 (detection time of speed error) are set incorrectly.	◇ Set P9-69 and P9-70 correctly based on actual condition.
Motor overspeed Problem	Err43	Encoder parameters are set improperly.	◇ Set encoder parameters properly.
		Motor auto-tuning is not performed.	◇ Perform motor auto-tuning.
		P9-67 (Overspeed detection level) and P9-68 (Overspeed detection time) are set incorrectly.	◇ P9-67 and P9-68 correctly based on actual condition.
Motor overtemperature	Err45	Cable connection of temperature sensor becomes loose	◇ Check cable connection of temperature sensor.
		The motor temperature is too high.	◇ Decrease carrier frequency or take other measures to cool the motor.
Initial position angle identification fault	Err51	AC drive output phase loss	◇ Check whether the motor wiring is correct.
		The AC drive current detection fails or the hall is damaged.	◇ Check the hall.

Fault Name	Operating Panel Display	Cause	Possible Solution
Initial position angle identification fault	Err51	The motor inductance is too large.	◇ Set P9-75 to avoid this fault.
Braking unit overload	Err61	Resistance of braking resistor is too small.	◇ Replace a braking resistor of larger resistance.
Short-circuit of braking circuit	Err62	Braking module is abnormal.	◇ Contact the agent or Inovance.
Counter electromotive force identification exception warning	A64	Related parameters are set incorrectly.	◇ Set related parameters correctly, the rated frequency and rotation speed in particular.
		P1-20 is set incorrectly.	◇ Check whether P1-20 is set to a too large or too small value.
		Counter electromotive force identification exception during dynamic identification	◇ Check whether the motor has no load during dynamic identification and whether the motor rotates at 40% of the rated rotation speed. If the motor has load and its speed is below 40% of the rated rotation speed, perform identification again after disconnecting the motor from load.
		The motor is demagnetized.	◇ Check whether the motor is demagnetized.
		Counter electromotive force is too large or too small.	◇ If yes, press STOP to reset the warning and the motor continues to run.

WARRANTY

- ❶ The company solemnly promises that users will enjoy the following warranty services from the date of purchase of products from our company (hereinafter referred to as the manufacturer).
- ❷ Since the product was purchased by the user from the manufacturer, enjoy the following three guarantee services:
 - ✘ Return, replacement and repair within 30 days of delivery:
 - ✘ Replacement and repair within 90 days of delivery:
 - ✘ Repair within 18 months of delivery:
 - ✘ Except when exporting abroad.
- ❸ This product enjoys lifetime paid service from the date of purchase by the user from the manufacturer.
- ❹ Disclaimer: Product failure caused by the following reasons is not covered by the manufacturer's free warranty service:
 - ✘ Failure caused by the user's use and operation in accordance with the requirements of the «Instruction Manual»:
 - ✘ Failure caused by the user to repair or modify the product without communicating with the manufacturer:
 - ✘ Failure caused by abnormal aging of the product due to poor user environment:
 - ✘ Failures caused by natural disasters such as earthquakes, fires, floods or abnormal voltages:
 - ✘ Damage to the product during transportation (the transportation method is specified by the customer, and the company assists in handling the cargo consignment procedures)
- ❺ Under the following conditions, manufacturers have the right not to provide warranty services:
 - ✘ When the manufacturer's product logo, trademark, nameplate, etc. are damaged or unrecognizable:
 - ✘ When the user fails to pay the purchase price in accordance with the signed contract:
 - ✘ The user intentionally conceals the manufacturer's after-sales service unit when the product is installed, wired, operated, maintained or otherwise improperly used
- ❻ For the service of return, replacement and repair, the company must return or return to the company, and it can only be returned or repaired after confirming the responsibility vested.

WARRANTY CARD

User information			
User name			
User address			
Postal code		Contact person	
Tel		Fax	
Machine type		Machine code	
Agent / Reseller Information			
Supplier			
Contact			
Tel		Delivery date	

CERTIFICATE OF QUALITY

QC test: _____

This product has been tested by our company's quality department, and its performance meets the standards, passes the inspection, and is approved to leave the factory.

